

**Technical training.**  
**Product information.**

## **N63TU2 Engine**



**BMW Service**

Edited for the U.S. market by:  
**BMW Group University**  
**Technical Training**

ST1511

9/1/2015

# General information

## Symbols used

The following symbol is used in this document to facilitate better comprehension or to draw attention to very important information:



---

Contains important safety information and information that needs to be observed strictly in order to guarantee the smooth operation of the system.

---

## Information status and national-market versions

BMW Group vehicles meet the requirements of the highest safety and quality standards. Changes in requirements for environmental protection, customer benefits and design render necessary continuous development of systems and components. Consequently, there may be discrepancies between the contents of this document and the vehicles available in the training course.

This document basically relates to the European version of left-hand drive vehicles. Some operating elements or components are arranged differently in right-hand drive vehicles than shown in the graphics in this document. Further differences may arise as the result of the equipment specification in specific markets or countries.

## Additional sources of information

Further information on the individual topics can be found in the following:

- Owner's Handbook
- Integrated Service Technical Application.

Contact: [conceptinfo@bmw.de](mailto:conceptinfo@bmw.de)

©2015 BMW AG, Munich

## Reprints of this publication or its parts require the written approval of BMW AG, Munich.

The information contained in this document forms an integral part of the technical training of the BMW Group and is intended for the trainer and participants in the seminar. Refer to the latest relevant information systems of the BMW Group for any changes/additions to the technical data.

### Contact:

Achim Gloede

Tel.: +49 (0) 89 382 50398

E-mail: [achim.gloede@bmw.de](mailto:achim.gloede@bmw.de)

Information status: **May 2015**

**BV-72/Technical Training**

# N63TU2 Engine

## Contents

<b>1.</b>	<b>Introduction</b> .....	<b>1</b>
1.1.	Models.....	1
1.2.	Technical data.....	1
1.2.1.	Full load diagram .....	3
1.3.	New features on the N63TU2 engine.....	4
1.3.1.	Overview.....	4
1.3.2.	N63TU2 engine components.....	5
1.4.	Engine identification.....	11
1.4.1.	Engine designation.....	11
1.4.2.	Engine identification.....	11
<b>2.</b>	<b>Engine Mechanical</b> .....	<b>13</b>
2.1.	Engine housing.....	13
2.1.1.	Crankcase.....	13
2.1.2.	Cylinder head gasket.....	15
2.1.3.	Cylinder head.....	16
2.1.4.	Cylinder head cover.....	18
2.1.5.	Oil sump.....	25
2.2.	Crankshaft drive.....	27
2.2.1.	Crankshaft with bearings.....	28
2.2.2.	Flywheel.....	29
2.2.3.	Connecting rod with bearing.....	30
2.2.4.	Piston with piston rings.....	32
2.3.	Camshaft drive/chain drive.....	34
2.4.	Valve gear.....	35
2.4.1.	Design.....	35
2.4.2.	Valvetronic.....	39
2.5.	Belt drive.....	50
2.6.	SynTAK (synergy thermo-acoustic capsule).....	51
<b>3.</b>	<b>Oil Supply</b> .....	<b>52</b>
3.1.	Overview.....	52
3.1.1.	Hydraulic circuit diagram.....	52
3.2.	Oil pump and pressure control.....	54
3.2.1.	Intake neck.....	54
3.2.2.	Oil pump.....	55
3.2.3.	Map control valve.....	57
3.2.4.	Normal operation.....	59
3.2.5.	Emergency operation.....	60
3.3.	Oil cooling and filtering.....	62
3.3.1.	Oil cooling.....	63

# N63TU2 Engine

## Contents

3.3.2.	Oil filtering.....	65
3.4.	Oil monitoring.....	65
3.4.1.	Oil level.....	65
3.4.2.	Oil pressure sensor.....	65
3.4.3.	Oil temperature sensor.....	66
3.5.	Oil spray nozzles.....	66
3.5.1.	Piston crown cooling.....	66
3.5.2.	Chain drive.....	67
3.5.3.	Camshaft.....	68
3.5.4.	Valvetronic servomotor.....	68
<b>4.</b>	<b>Cooling.....</b>	<b>69</b>
4.1.	System overview.....	70
4.1.1.	Cooling circuit, engine .....	71
4.1.2.	Cooling circuit of charge air cooler and DME.....	83
4.2.	Heat management.....	86
4.2.1.	Auxiliary water pump.....	86
4.2.2.	Data-map thermostat.....	87
4.2.3.	Coolant temperature sensor.....	96
<b>5.</b>	<b>Intake Air and Emission System.....</b>	<b>97</b>
5.1.	Overview.....	97
5.2.	Intake air system.....	99
5.2.1.	Hot film air mass meter.....	100
5.2.2.	Intake silencer.....	101
5.2.3.	Intake manifold.....	101
5.3.	Exhaust turbocharger.....	102
5.3.1.	Charging pressure control.....	103
5.3.2.	Function.....	104
5.4.	Exhaust emission system.....	105
5.4.1.	Exhaust manifold.....	105
5.4.2.	Catalytic converter.....	106
5.4.3.	Exhaust system.....	108
5.4.4.	Electrically controlled exhaust flaps.....	110
<b>6.</b>	<b>Vacuum System.....</b>	<b>112</b>
<b>7.</b>	<b>Fuel Preparation.....</b>	<b>113</b>
7.1.	Overview.....	113
7.2.	Fuel pump control.....	114
7.3.	High pressure pump.....	114

# N63TU2 Engine

## Contents

7.4.	Injectors.....	115
<b>8.</b>	<b>Fuel Supply.....</b>	<b>116</b>
<b>9.</b>	<b>Engine Electrical System.....</b>	<b>117</b>
9.1.	Overview.....	117
9.2.	Engine control unit.....	124
	9.2.1. Overall function.....	126
9.3.	Alternator.....	127



# N63TU2 Engine

## 1. Introduction

The N63TU2 engine replaces the predecessor N63TU. The key enhancements of the N63TU2 over the N63TU are the improved exhaust-gas characteristics, the availability of the engine torque over a wider speed range together with optimized consumption, and a more efficient production process in the plant for the new N63TU2 engine.

The unique selling points of the new N63TU2 engine for the market include innovative detailed solutions such as the internal engine thermal management system during warm-up (called SCC, "**Split Cooling Combined**"), the engine oil/coolant heat exchanger integrated into the engine V, the half-shell intake system and the engine charging using the twin-scroll exhaust turbocharger technology.

The new N63TU2 engine will be introduced into series production for the first time with the new G12.

In this documentation the differences to the N63TU predecessor engine are described.

### 1.1. Models

Development series	N63B44O2 engine	Series introduction
G12	BMW 750i BMW 750i xDrive	07/2015

### 1.2. Technical data

Engine	Unit	N63B44O1	N63B44O2
Development series		F02 LCI	G12
Model designation		BMW 750i	BMW 750i
Design		V8	V8
Displacement	[cm <sup>3</sup> ]	4395	4395
Firing order		1-5-4-8-6-3-7-2	1-5-4-8-6-3-7-2
Bore/stroke	[mm]	89/88.3	89/88.3
Power output at engine speed	[kW (HP)] [rpm]	330 (445) 5,500 - 6,000	330 (445) 5,500 - 6,000
Cutoff speed	[rpm]	6,500	6,500
Power output per liter	[kW/l]	75/1	75/1
Torque at engine speed	[Nm (lb-ft)] [rpm]	650 (480) 2,000 - 4,500	650 (480) 1,800 - 4,500
Compression ratio	[ε]	10.0	10.5
Valves per cylinder		4	4
Fuel	[RON]	91 - 98	91 - 98
Fuel consumption complying with EU	[l/100 km]	8.6	-
CO <sub>2</sub> emissions	[grams per kilometer]	199	-

# N63TU2 Engine

## 1. Introduction

<b>Engine</b>	<b>Unit</b>	<b>N63B44O1</b>	<b>N63B44O2</b>
Digital Motor Electronics		MEVD 17.2.8	DME 8.8
Exhaust emissions legislation		ULEV II	ULEV II
Maximum speed	[km/h]	250	250
Acceleration 0–100 (0–62) km/h (mph)	[s]	4.8	-

The data on consumption/acceleration and CO<sub>2</sub> emissions for this model was unavailable at the time this document was created.



# N63TU2 Engine

## 1. Introduction

### 1.2.1. Full load diagram

N63TU engine in the F01 LCI/N63TU2 engine in the G12

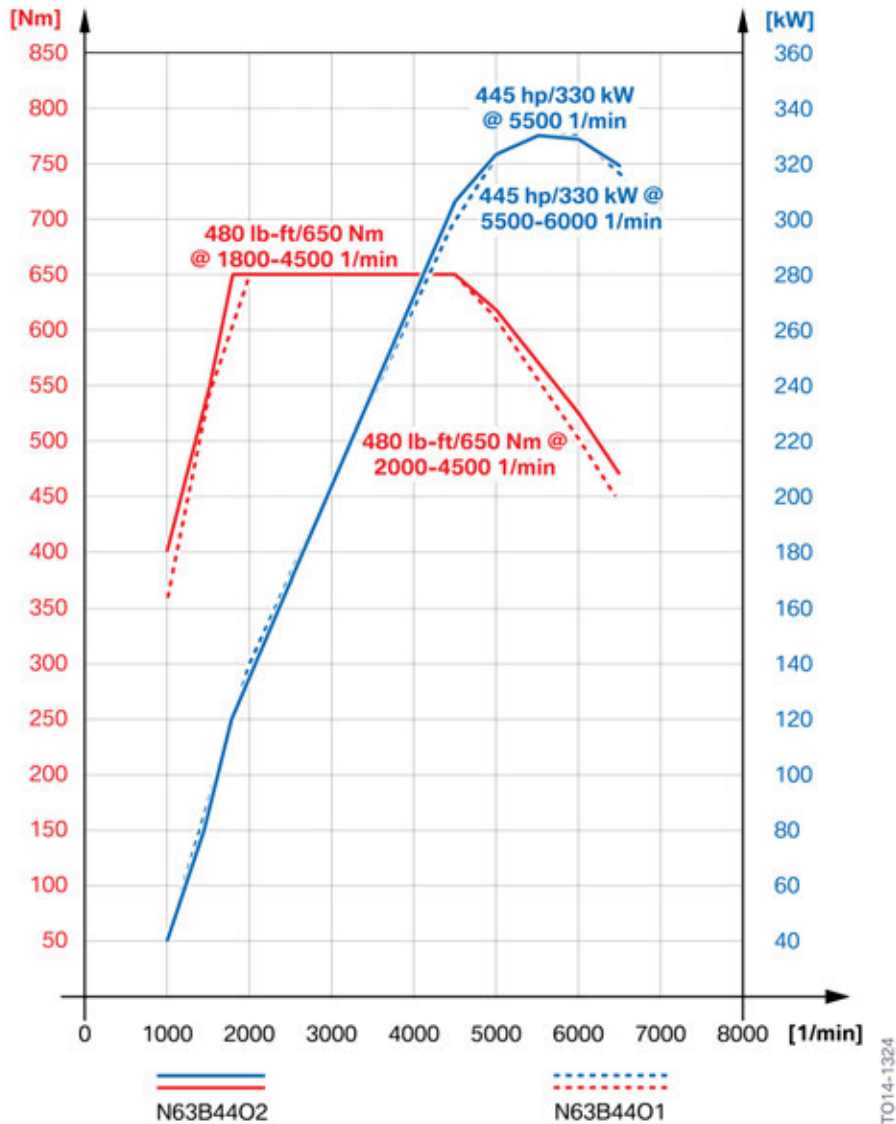

Full load diagram, N63B44O2 engine compared to the N63B44O1 engine

# N63TU2 Engine

## 1. Introduction

### 1.3. New features on the N63TU2 engine

#### 1.3.1. Overview

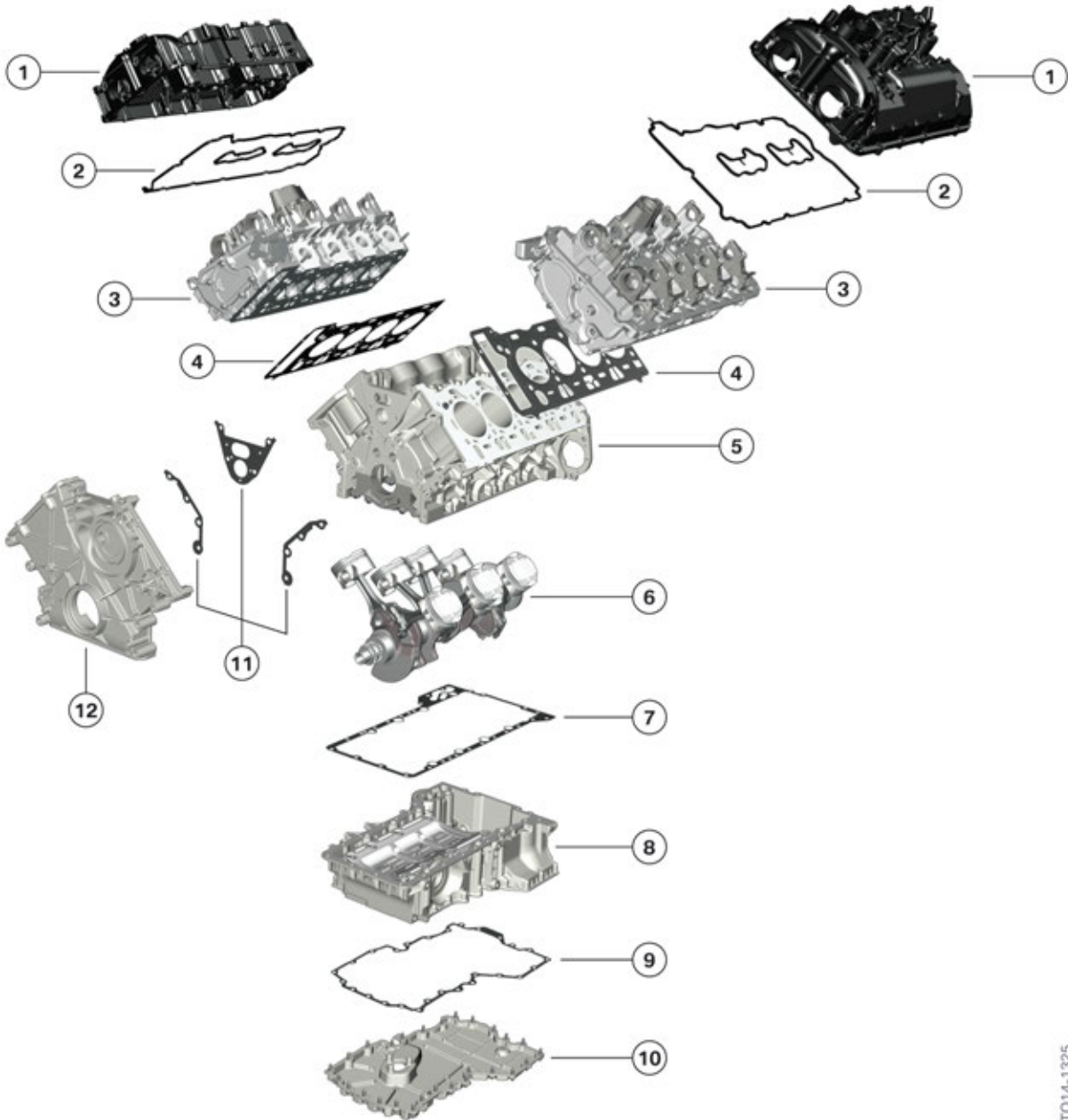

N63TU2 engine, exploded diagram

TO14-1325

# N63TU2 Engine

## 1. Introduction

Index	Explanation
1	Cylinder head cover
2	Cylinder head cover gasket
3	Cylinder head
4	Cylinder head gasket
5	Crankcase
6	Crankshaft drive
7	Oil sump gasket, top
8	Oil sump, top
9	Oil sump gasket, bottom
10	Oil sump, bottom
11	Timing case cover gasket
12	Timing case cover

### 1.3.2. N63TU2 engine components

#### Engine mechanics

Component	New feature	Identical concept	Carry-over part	Comment
Cylinder head cover		●		Modified to accommodate VANOS solenoid valves.
Cylinder head	●			Partial integration of the intake neck into the cylinder head. Optimized weight – weight saving of 1.5 kg per cylinder head compared to the N63TU engine. Mountings for VANOS solenoid valves removed Ducts for directing the engine oil simplified. Internal engine thermal management system integrated.
Cylinder head gasket		●		Revised cylinder head gasket at water passages for the thermal management system. Changeover to partial screen printing coating.
Crankcase	●			Internal engine thermal management system integrated. Modified to accommodate the engine oil/coolant heat exchanger. Ducts for directing the engine oil simplified.

# N63TU2 Engine

## 1. Introduction

Component	New feature	Identical concept	Carry-over part	Comment
Crankshaft with main bearing			●	Taken over from N63TU engine.
Connecting rod			●	Taken over from N63TU engine.
Gudgeon pin			●	Taken over from N63TU engine.
Connecting rod bearing shells		●		Material changed over to steel/aluminium anti-friction coating (IROX).
Piston	●			Oil scraper ring groove modified from 4 to 8 oil drains. Modified to accommodate a higher compression ratio.
Piston rings			●	Taken over from N63TU engine. Width of oil scraper ring. reduced from 2 mm to 1.8 mm.
Flywheel	●			Three-part flywheel (four-part on the N63TU). 0.52 kg weight reduction .
SynTAK	●			Synergy thermoacoustic capsule. Provides acoustic and thermal insulation.

### Valve gear

Component	New feature	Identical concept	Carry-over part	Comment
Chain drive with timing chain			●	Taken over from N63TU engine.
VANOS			●	Taken over from modular engines. Increased adjustment speed and reduced susceptibility to dirt.
Fully variable valve lift adjustment			●	Taken over from N63TU engine. Gate only screwed using one screw, as on modular engines.

# N63TU2 Engine

## 1. Introduction

Component	New feature	Identical concept	Carry-over part	Comment
Intake valves and exhaust valves		●		Chrome-plated valve stems.
Valve guides		●		Material changed over to high-temperature-resistant brass.
Camshafts		●		Modified mountings to accommodate VANOS units from modular engines. Exhaust camshaft with modified timing.

### Belt drive and ancillary components

Component	New feature	Identical concept	Carry-over part	Comment
Vibration damper		●		Optimized weight (500 g lighter than on the N63TU).
Belt drive		●		Concept taken over from the N63TU engine. Belt pulley for crankshaft is new and made from high-strength plastic. Belt level moved forwards by 20 mm. Air conditioning compressor arranged on the right of the engine.

# N63TU2 Engine

## 1. Introduction

### Oil supply

Component	New feature	Identical concept	Carry-over part	Comment
Oil pump	●			Characteristic map-controlled pendulum slide pump.
Oil sump	●			Two versions for rear-wheel drive and four-wheel drive. Four-wheel drive with aperture for front-wheel drive. Rear-wheel drive with sealed side boxes for optimal use of the available space.
Oil filter module	●			Oil pressure sensor and characteristic map control valve integrated.
Oil spray nozzles	●			Modified opening pressure and closing pressure.

### Air intake and exhaust emission systems

Component	New feature	Identical concept	Carry-over part	Comment
Intake manifold	●			Half-shell intake system used.
Exhaust manifold	●			Adapted to the twin-scroll turbocharger concept.
Exhaust turbocharger	●			Twin-scroll concept. Electrical wastegate valves.
Exhaust system	●			Optimized for minimal exhaust gas pressure. Electrical exhaust flaps. Active Sound Design (ASD) in the passenger compartment.
Heat shields			●	Taken over from N63TU engine. Top heat shield adapted to twin-scroll concept.
Upstream catalytic converter		●		

### Vacuum system

Component	New feature	Identical concept	Carry-over part	Comment
Vacuum pump			●	Taken over from N63TU engine. Auxiliary consumers removed.

# N63TU2 Engine

## 1. Introduction

### Fuel preparation

Component	New feature	Identical concept	Carry-over part	Comment
High pressure pump		●		Bank-specific with modified inlet connector.
Injectors			●	Taken over from N63TU engine.

### Cooling

Component	New feature	Identical concept	Carry-over part	Comment
Engine oil-to-coolant heat exchanger	●			Engine oil/air heat exchanger removed from front of vehicle, replaced by engine oil/coolant heat exchanger in engine V.
High-temperature circuit Engine cooling		●		Additional electric coolant pump for exhaust turbocharger.
Mechanical coolant pump		●		Further developed into a characteristic map-dependent coolant pump.
Characteristic map thermostat	●			With opening detection and return passages barrier.
Low-temperature circuit Charge air cooling		●		Indirect charge air cooling with 2 heat exchangers. Own coolant circuit. Electric coolant pump.

### Engine electrical system

Component	New feature	Identical concept	Carry-over part	Comment
Digital Motor Electronics DME	●			DME 8.8.0 Hardware from modular engines. Coolant cooling.
VANOS solenoid valves			●	Taken over from modular engines.
Valvetronic servomotor			●	Taken over from modular engines.
Hot film air mass meter			●	Hot film air mass meter 8 taken over from modular engines.

# N63TU2 Engine

## 1. Introduction

Component	New feature	Identical concept	Carry-over part	Comment
Oxygen sensors			●	Control sensor taken over from the N63TU engine (LSU ADV). Monitoring sensor taken over from modular engines (LSF Xfour).
Ignition coils		●		Extended ignition coils based on the N55 engine.
Spark plugs			●	Taken over from N63TU engine.
Knock sensors			●	Taken over from N63TU engine.
Oil temperature sensor			●	Taken over from N63TU engine.
Intake pipe pressure/temperature sensor			●	Taken over from N63TU engine.
Camshaft/crankshaft sensor			●	Taken over from modular engines. Can be recorded as a camshaft sensor or crankshaft sensor.
Coolant temperature sensor			●	Taken over from the N55 engine.
Oil pressure sensor	●			Oil pressure sensor instead of oil pressure switch in the N63TU.
Oil level sensor		●		Oil-level sensor based on oil-level sensor in the N63TU.
Rail pressure sensor			●	Taken over from the N63TU engine.
Electrical wastegate valve actuator			●	Taken over from the N55 engine.
Starter motor		●		Adapted to MSA 2.3.
Alternator			●	Taken over from modular engines.
Electromotive throttle controller			●	Taken over from modular engines.



# N63TU2 Engine

## 1. Introduction

### 1.4. Engine identification

#### 1.4.1. Engine designation

The N63TU2 engine in version N63B44O2 is described in this documentation. The N63B40O2 engine in a different capacity class is also available for the Chinese market; however, this engine is not considered in this documentation. The basic design of the N63B40O2 engine is identical to that of the N63B44O2 engine. The reduced capacity is the result of a reduced piston stroke caused by a longer connecting rod and the reduced compression ratio.

In the technical documentation, the engine designation is used to ensure unambiguous identification of the engine.

The technical documentation also contains the short form of the engine designation N63TU2, which only indicates the engine type.

#### Itemization

Index	Explanation
N	BMW Group "New Generation"
6	V8 engine
3	Engine with exhaust turbocharger, Valvetronic and direct fuel injection (TVDI)
B	Gasoline engine installed longitudinally
44	4.4 liters displacement
O	Upper performance class
2	Second revision

#### 1.4.2. Engine identification

The engines have an identification mark on the crankcase to ensure unambiguous identification and classification. This engine identification is necessary for approval by government authorities. The first six positions of the engine identification correspond to the engine designation.

The engine number can be found on the engine above the engine identification. This consecutive number, in conjunction with the engine identification, permits unambiguous identification of each individual engine.

# N63TU2 Engine

## 1. Introduction

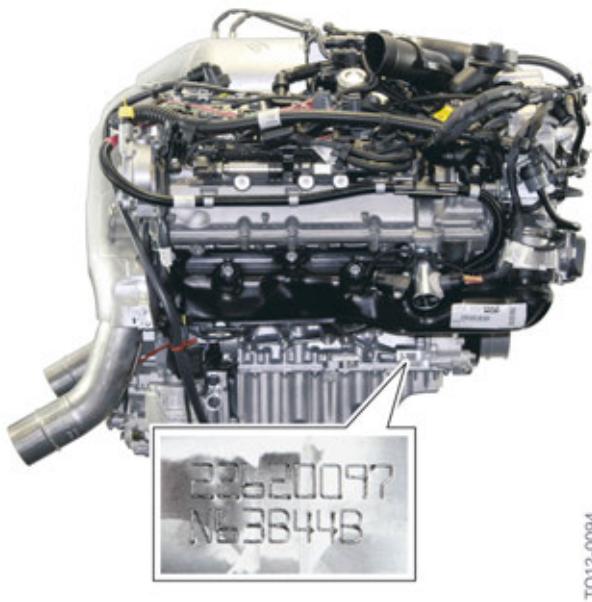

Example of an N63TU engine, engine identification and engine number

Index	Explanation
22620097	Individual, consecutive engine number
N	BMW Group "New Generation"
6	V8 engine
3	Engine with exhaust turbocharger, Valvetronic and direct fuel injection (TVDI)
B	Gasoline engine installed longitudinally
44	4.4 liters displacement
B	Type test concerns, standard

# N63TU2 Engine

## 2. Engine Mechanical

### 2.1. Engine housing

The engine housing comprises of the engine block, cylinder heads, cylinder head covers, oil sump and the gaskets.

#### 2.1.1. Crankcase

The crankcase on the N63TU2 engine has been completely redesigned and is manufactured from low-pressure die cast AlSi17Cu4Mg, as on the N63TU engine. The cylinder barrels are made from Alusil. Like its predecessor in the N63TU engine, the closed-deck crankcase in the N63TU2 engine is characterized by a double main bearing screw connection with side wall connection.

The crankcase cast part consists of the cylinder bores with Alusil coating, the bearing ways with the bore holes for the crankshaft and associated bearings and the water jackets of the cylinders. The water jackets of the crankcase and the water ducts in the cylinder head form the basis for the revised coolant passages inside the engine and the thermal management system of the N63TU2 engine. This design has also deleted the need for the coolant chamber sealing cap at the rear on the crankcase.

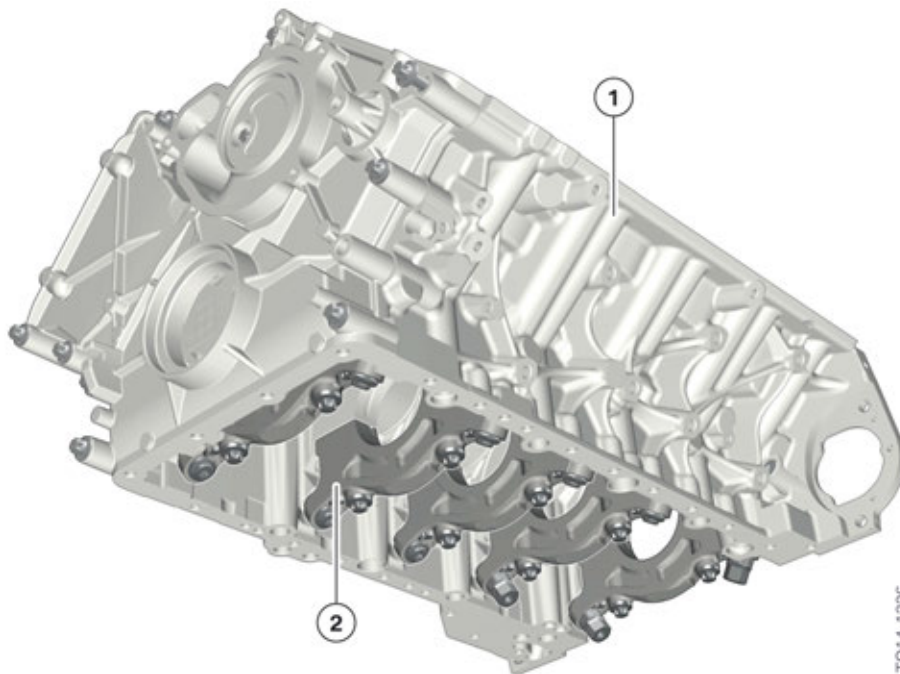

N63TU2 engine, crankcase with screw connections

Index	Explanation
1	Crankcase
2	Double main bearing screw connection with side wall connection

The V area of the N63TU2 has been adapted to the crankcase with regard to the attachment of the engine oil/coolant heat exchanger. The oil holes as well as the water ducts in the crankcase have been adapted to the connection required for the engine oil/coolant heat exchanger.

# N63TU2 Engine

## 2. Engine Mechanical

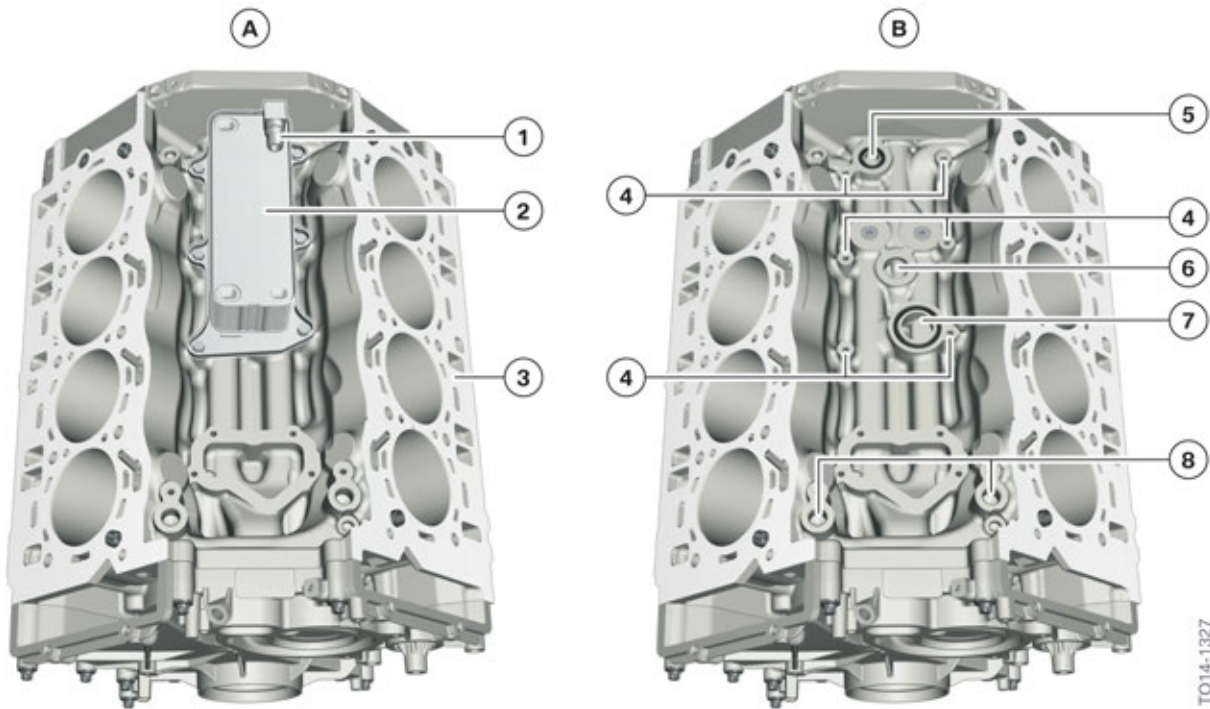

N63TU2 engine, crankcase

Index	Explanation
A	Crankcase with engine oil/coolant heat exchanger
B	Crankcase without engine oil/coolant heat exchanger
1	Coolant return from engine oil/coolant heat exchanger
2	Engine oil-to-coolant heat exchanger
3	Crankcase
4	6x screw connection for the engine oil/coolant heat exchanger
5	Oil return from engine oil/coolant heat exchanger
6	Oil supply to engine oil/coolant heat exchanger
7	Coolant supply to engine oil/coolant heat exchanger
8	Oil supply for exhaust turbocharger

# N63TU2 Engine

## 2. Engine Mechanical

### 2.1.2. Cylinder head gasket

As on the N63TU engine, a three-layer spring steel gasket is used for the cylinder head gasket. There is a stopper plate (2) in the area of the cylinder bores in order to achieve sufficient contact pressure for sealing.

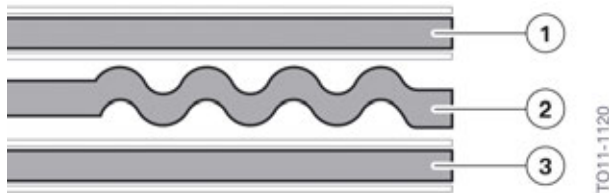

N63TU2 engine, cylinder head gasket

Index	Explanation
1	Top spring steel layer with anti-stick coating
2	Stopper layer
3	Bottom spring steel layer with anti-stick coating

In contrast to the N63TU engine, on the N63TU2 the contact surfaces with the cylinder head and engine block are no longer fully coated, but instead have partial screen printing coating. By omitting the coating in the coolant duct areas, the risk of the coating coming loose and contaminating the coolant circuit is minimized.

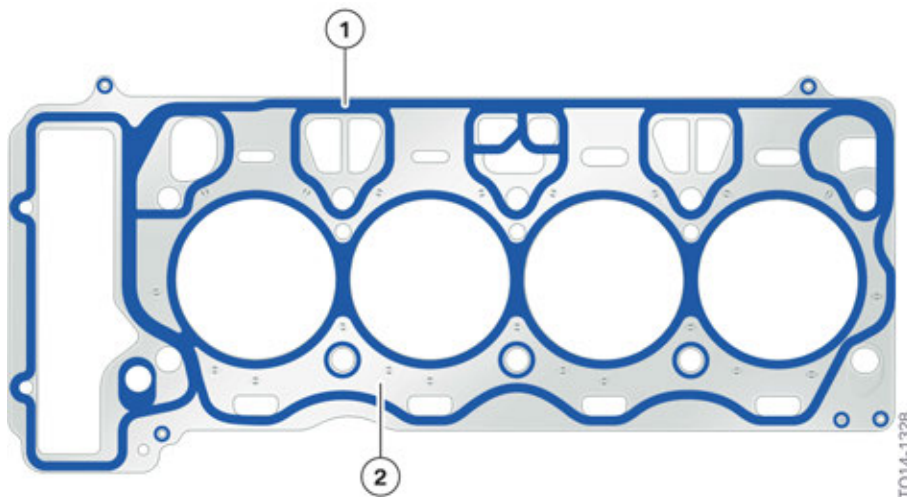

N63TU2 engine, cylinder head gasket coating

Index	Explanation
1	Partial screen printing coating
2	Cylinder head gasket

# N63TU2 Engine

## 2. Engine Mechanical

### 2.1.3. Cylinder head

The cylinder head of the N63TU2 engine is a new feature with partially integrated intake system. Thanks to this partially integrated intake system in the cylinder head, the passages characteristics of the incoming air has been optimized and the space required to install the intake pipe has been significantly reduced. It has also allowed the weight of the cylinder head to be reduced by 1.5 kg / 3.3 lbs.

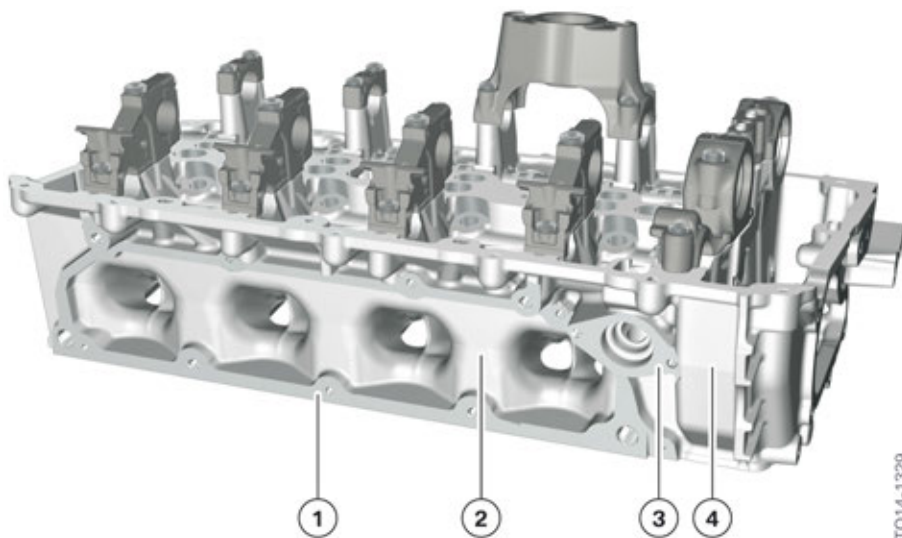

N63TU2 engine, cylinder head

Index	Explanation
1	Sealing flange for intake system
2	Partially integrated intake pipe
3	Flange for Valvetronic servomotor
4	Cylinder head bank 1

With the exception of the combustion chamber dome and the valve gear (which have been taken over from the N63TU), the cylinder head is a completely new component in the N63TU2 engine. The coolant passages in the cylinder head are separate from the coolant passages around the cylinder bores. By taking over the VANOS solenoid valves into the cylinder head cover and the VANOS adjusters (as is already the case for the N20 engine and the modular engines), the bore holes for the VANOS solenoid valves in the cylinder head could be removed, meaning the associated engine oil ducts in the cylinder head can also be simplified.

3rd-generation Valvetronic technology is also used in the N63TU2 engine, as is already the case in the N55 and N63TU engines. The Valvetronic servomotor is connected on the outer side at the cylinder head.



The combination of exhaust turbocharger, Valvetronic and direct fuel injection is known as **Turbo Valvetronic Direct Injection (TVDI)**.

# N63TU2 Engine

## 2. Engine Mechanical

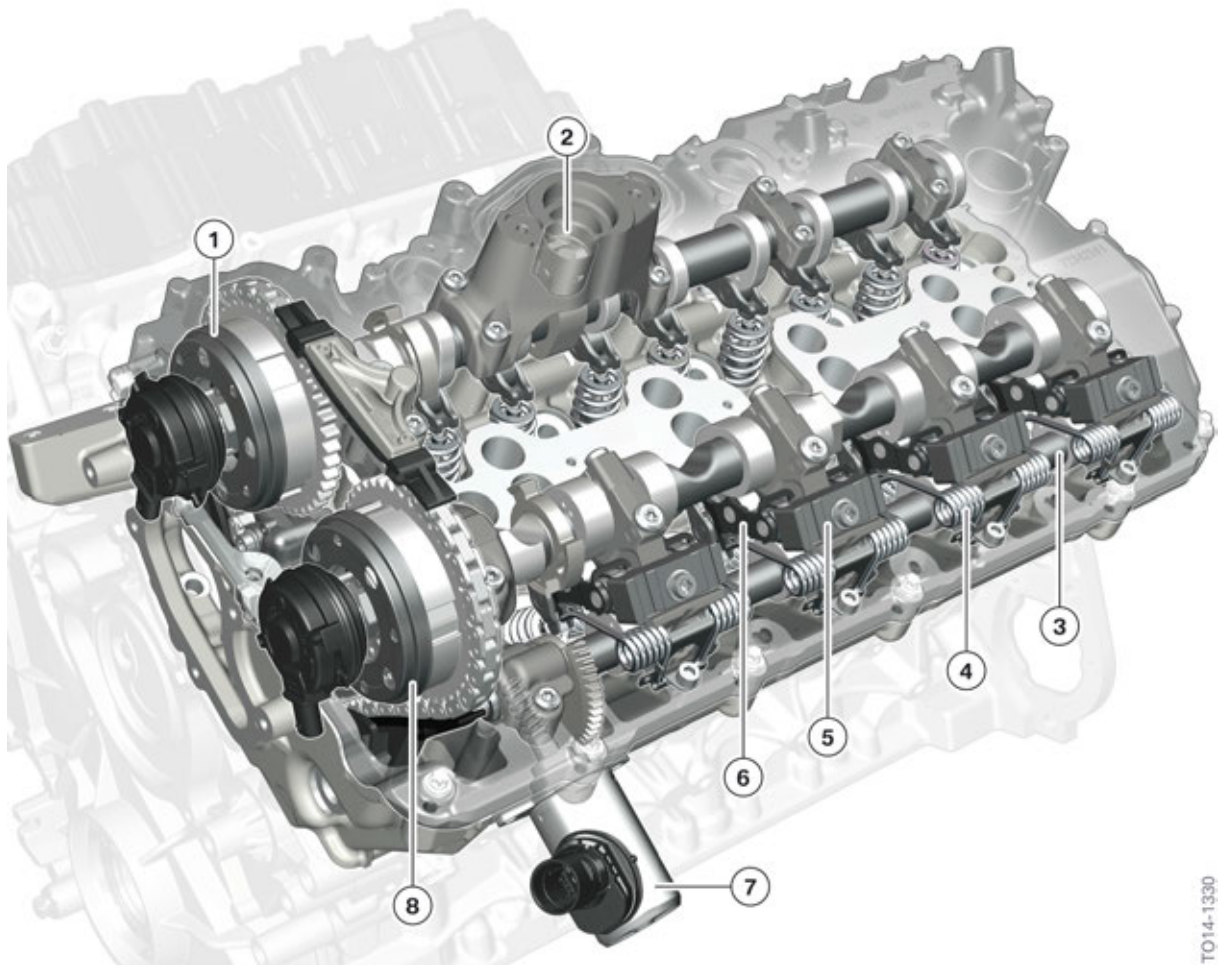

TO14-1330

N63TU2 engine, cylinder head with Valvetronic

Index	Explanation
1	VANOS, exhaust side
2	Roller tappet, high-pressure pump
3	Eccentric shaft
4	Torsion spring
5	Gate/guide block
6	Intermediate lever
7	Valvetronic servomotor
8	VANOS, intake side

# N63TU2 Engine

## 2. Engine Mechanical

### 2.1.4. Cylinder head cover

#### Design

The design of the cylinder head cover in the N63TU2 engine is the same as for the N63TU engine, but with minor modifications to the crankcase ventilation and the mountings for the VANOS solenoid valves. As in the N63TU, a ventilation register with an additional ventilation line is used. Each bank has its own oil separator. An additional line from the crankcase ventilation to the air intake system is not used as corresponding bore holes for the individual intake ports are integrated in the cylinder head.

The camshaft sensors are positioned on the front of the cylinder head cover.

To separate the oil contained in the blow-by gas, a labyrinth oil separator is used. A pre-separator (7) and a fine deflection plate with small air vents (6) are in the passages direction. The oil drops are separated at these barriers and return to the cylinder head via the return line (9 and 10). An impact surface (5) with an upstream mesh that ensures further separation of oil particles. The oil return (10) is equipped with a non-return valve in order to prevent direct intake of blow-by gasses without separation. If the oil level increases in this pipe, the non-return valve opens and the oil drops into the cylinder head. Finally, depending on the operating condition of the engine, the cleaned blow-by gases are fed back into the intake system either via the non-return valve (1) or via the volume control valve (12 and 3).

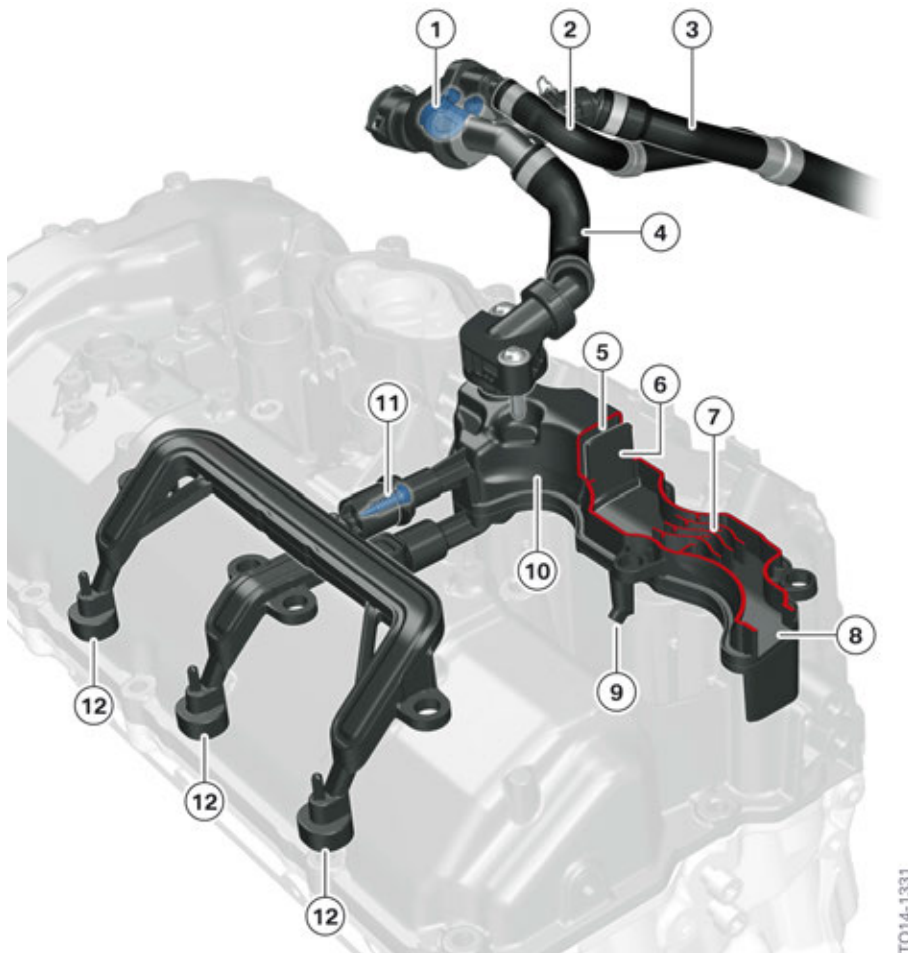

TO14-1331

N63TU2 engine, cylinder head cover with crankcase ventilation



# N63TU2 Engine

## 2. Engine Mechanical

Index	Explanation
1	Non-return valve for the clean air pipe with leak hole
2	Purge air line
3	Intake pipe with volume control valve
4	Line to clean air pipe
5	Impact surface with upstream mesh that
6	Fine deflector plate with small air vents
7	Pre-separator
8	Inlet for blow-by gases
9	Oil return
10	Oil separator
11	Volume control valve for the air intake system with throttle function
12	Connecting line via blow-by-gas channel for the intake port

### **Crankcase ventilation in naturally aspirated engine operation**

In the naturally aspirated engine operation there is a vacuum in the air intake system (12). The two volume control valves (3) are opened. The cleaned blow-by gases reach the inlet areas of both banks and thus the air intake system through the left oil separator via the intake pipe (5) and ducts in the cylinder head (19). As there is a risk that oil may be drawn in via the crankcase ventilation in the case of large vacuums, the volume control valve has a throttle function and limits the passages and thus also the pressure level in the crankcase.

The vacuum in the crankcase ventilation keeps the non-return valves (2 and 6) closed. Fresh air flows from the two clean air pipes through the right oil separator into the inside of the engine via the overlying leakage holes. The vacuum in the crankcase ventilation is thus restricted. At the same time the chemical ageing of the lubricating oil and also the water content in the blow-by gases are reduced by flushing the crankcase with fresh air.

# N63TU2 Engine

## 2. Engine Mechanical

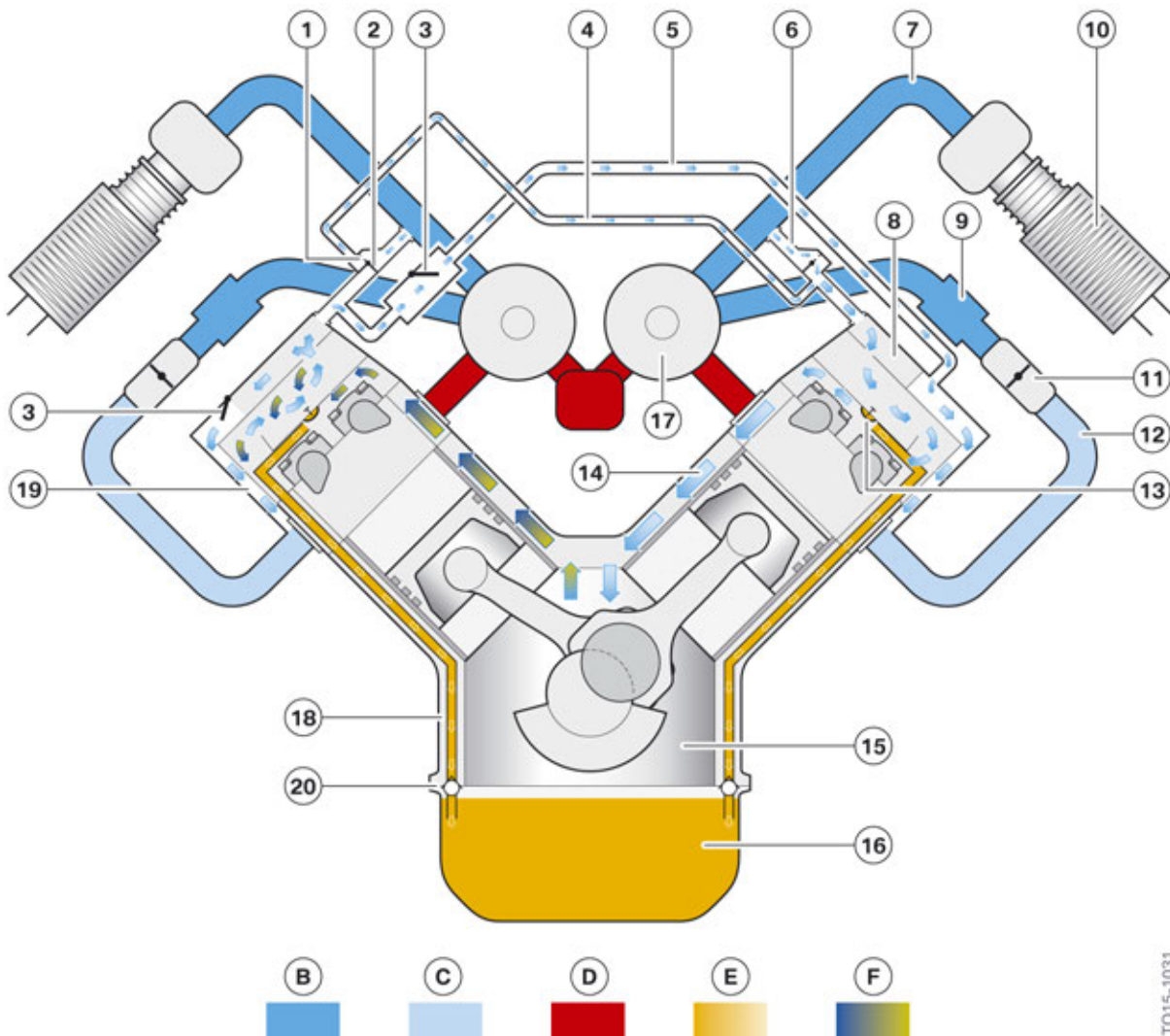

N63TU2 engine, overview of crankcase ventilation in the naturally aspirated engine operation

Index	Explanation
B	Ambient pressure
C	Vacuum
D	Exhaust gas
E	Oil
F	Blow-by gases
1	Leakage hole in the housing of the non-return valve
2	Non-return valve for the clean air pipe
3	Volume control valve for the air intake system with throttle function
4	Purge air line
5	Intake system from bank 2 to bank 1

# N63TU2 Engine

## 2. Engine Mechanical

Index	Explanation
6	Line to the clean air pipe with non-return valve and leakage hole
7	Clean air pipe
8	Oil separator
9	Charge air cooler
10	Intake silencer with hot film air mass meter 8
11	Throttle valve
12	Intake manifold
13	Oil return
14	Ventilation duct
15	Crank chamber
16	Oil sump
17	Exhaust turbocharger
18	Oil return duct
19	Duct in the cylinder head
20	Non-return valve

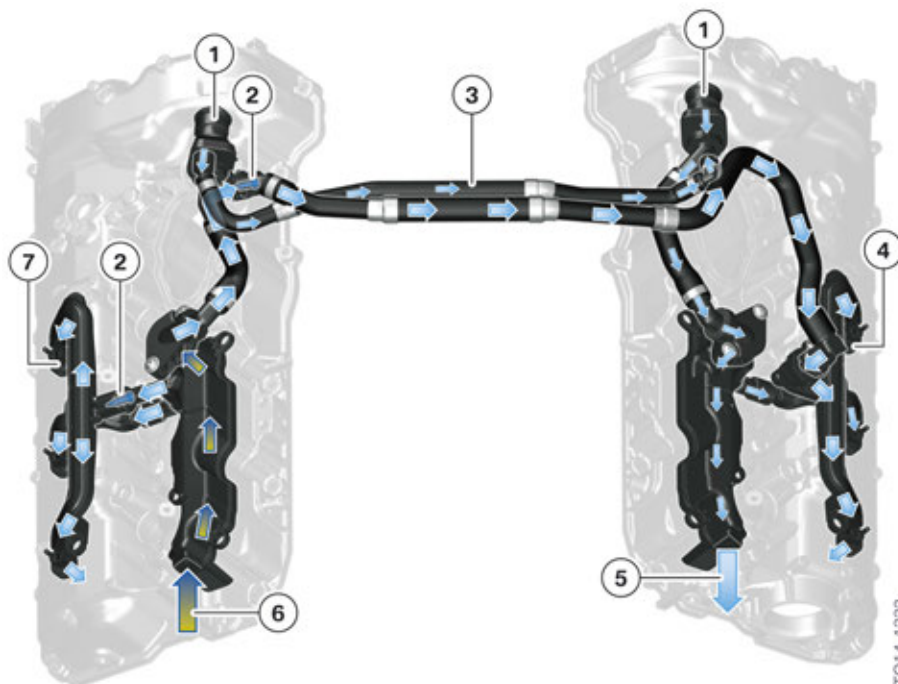

N63TU2 engine, components of the crankcase ventilation in the naturally aspirated engine operation

# N63TU2 Engine

## 2. Engine Mechanical

Index	Explanation
1	Fresh air supply via leakage holes when non-return valves are closed
2	Volume control valves open
3	Purge air line
4	Inlet of the blow-by gases to the inlet area of the cylinder head
5	Supply of scavenging air via the oil separator to the crankcase
6	Intake of blow-by gases to the oil separator
7	Intake of the cleaned blow-by gases into the inlet area of the cylinder head via ducts

### Crankcase ventilation in charged operation

In charged operation the pressure in the intake system (12) increases and thus closes the volume control valves (3). As there is a vacuum in this operating condition in the clean air pipe (7), the non-return valves (2 and 6) for the clean air pipe thus open and the cleaned blow-by gases are conveyed via the compressor of the exhaust turbocharger and the charge air cooler (9) into the air intake system.

# N63TU2 Engine

## 2. Engine Mechanical

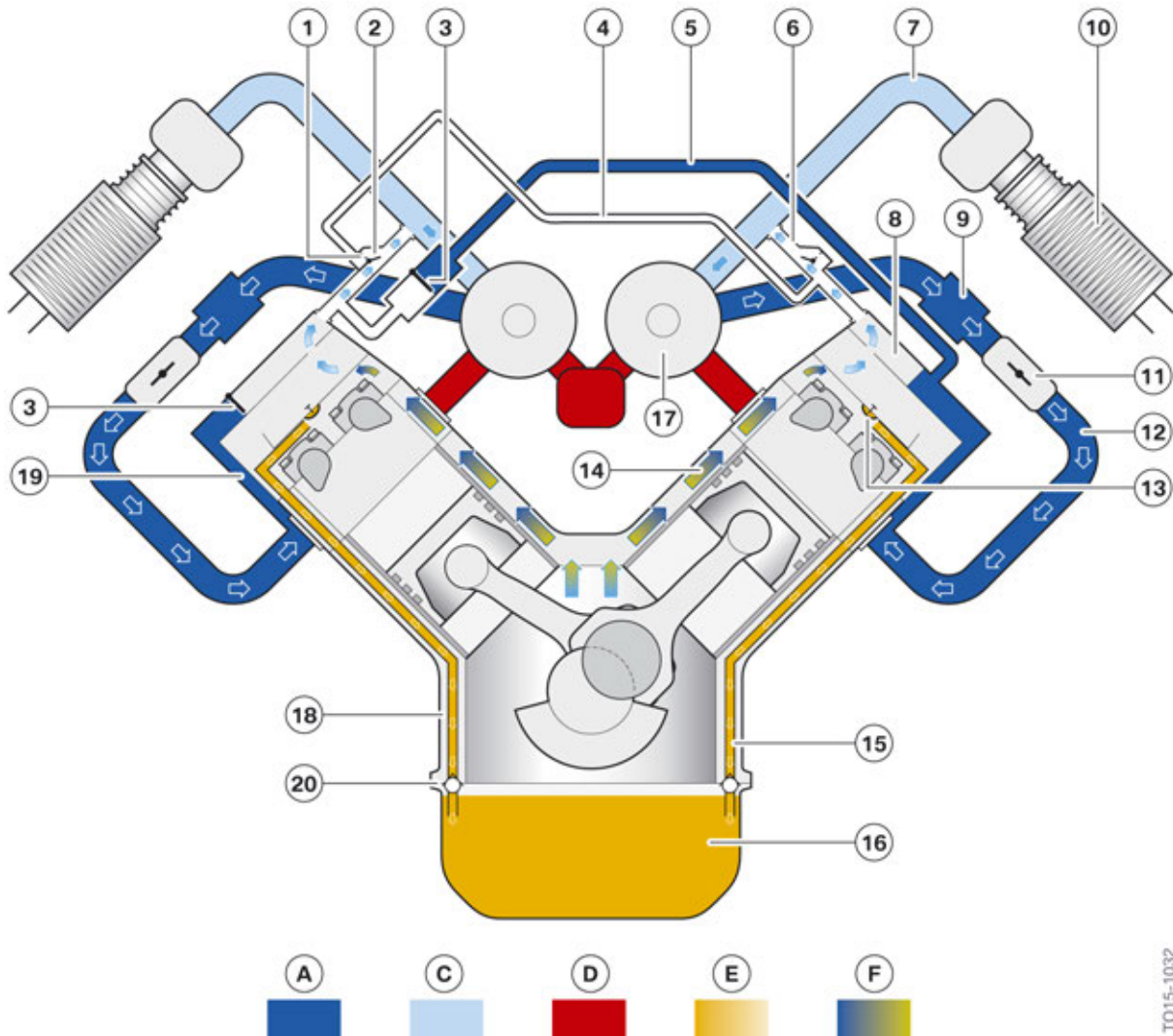

N63TU2 engine, overview of ventilation in charged operation

TO15-1032

Index	Explanation
A	Charging pressure $2.5^{+0.3}$ bar absolute
C	Vacuum
D	Exhaust gas
E	Oil
F	Blow-by gases
1	Leakage hole in the housing of the non-return valve
2	Non-return valve for the clean air pipe open
3	Volume control valves for the intake system with throttle function, closed
4	Purge air line
5	Intake pipe from bank 2 to bank 1

# N63TU2 Engine

## 2. Engine Mechanical

Index	Explanation
6	Line to the clean air pipe with open non-return valve
7	Clean air pipe
8	Oil separator
9	Charge air cooler
10	Intake silencer with hot film air mass meter 8
11	Throttle valve
12	Intake manifold
13	Oil return
14	Ventilation duct
15	Crank chamber
16	Oil sump
17	Exhaust turbocharger
18	Oil return duct
19	Duct in the cylinder head
20	Non-return valve

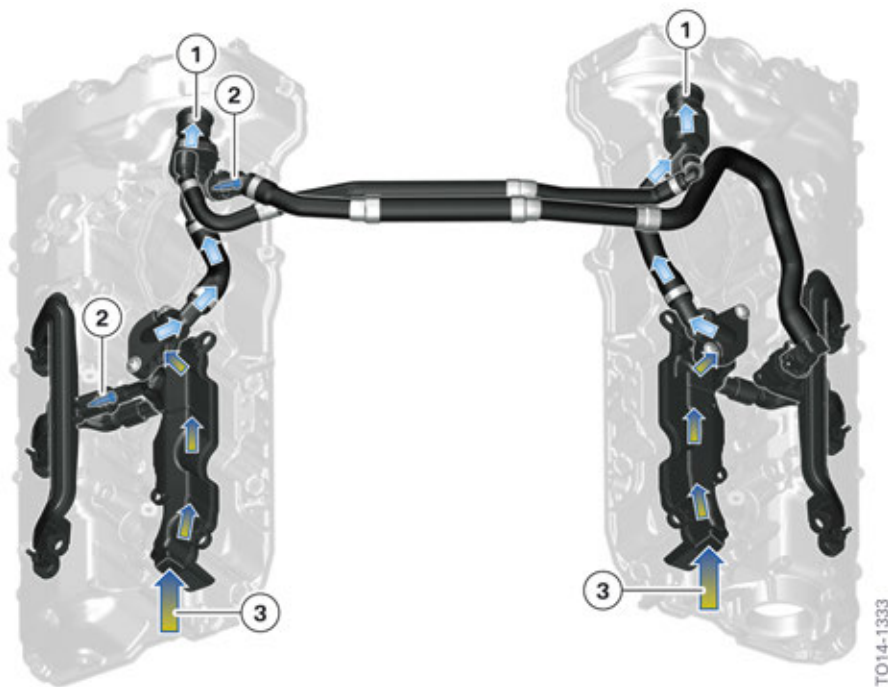

N63TU2 engine, components of the crankcase ventilation in charged operation

# N63TU2 Engine

## 2. Engine Mechanical

Index	Explanation
1	Non-return valves for the clean air pipe open
2	Volume control valves closed
3	Intake of blow-by gases to the oil separator

### 2.1.5. Oil sump

The oil sump is made from die-cast aluminium. In the N63TU2 engine it has a two-part design and consists of an upper and a lower oil sump section. The oil filter is integrated in the upper oil sump section.

2 different oil sumps are used depending on the drive concept. On rear-wheel drive vehicles a completely new design is used that offers the maximum possible oil volume thanks to its screwed and permanently sealed side boxes, which make the best possible use of the available space. For rear-wheel drive vehicles, the oil sump for the N63TU2 engine is identical for all planned vehicles with this drive concept.

The oil sump for four-wheel drive vehicles is also a new design. In addition to the drive shaft tunnel for front-wheel drive, it also supports the front axle differential at the designated, cast flange surfaces. For vehicles with four-wheel drive, the oil sump in the N63TU2 engine is also identical for all planned vehicles with this drive concept.

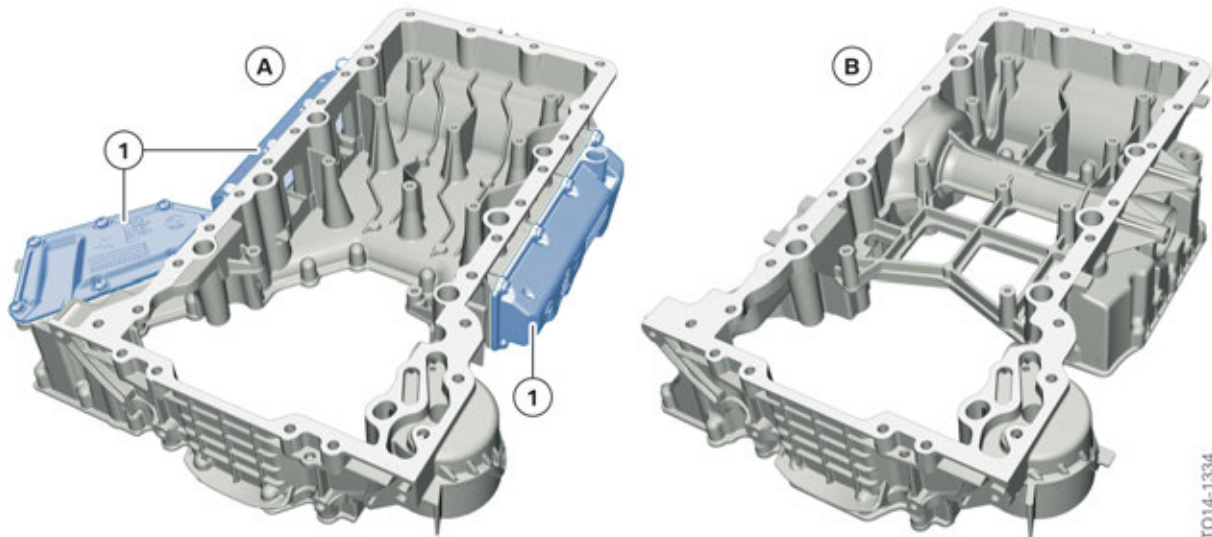

N63TU2 engine, oil sump variants

Index	Explanation
1	Screwed side boxes
A	Oil sump for rear-wheel drive
B	Oil sump for four-wheel drive

The oil filter module is integrated into the upper oil sump section on the left-hand side of the engine. The oil pressure sensor and the characteristic map control valve for the characteristic map-controlled oil pump are screwed to the upper section of the oil filter module.

# N63TU2 Engine

## 2. Engine Mechanical

The upper oil sump section is screwed to the crankcase using a beaded metal gasket. The lower oil sump section is likewise screwed to the upper oil sump section. Like the upper oil sump section, the lower oil sump section is made from die-cast aluminium and supports the oil-level sensor and oil drain plug.

The oil pump is screwed to the crankcase and is driven by the crankshaft via a chain. As on the N63TU engine, the oil deflector is integrated into the upper oil sump section and has been taken over from this model.

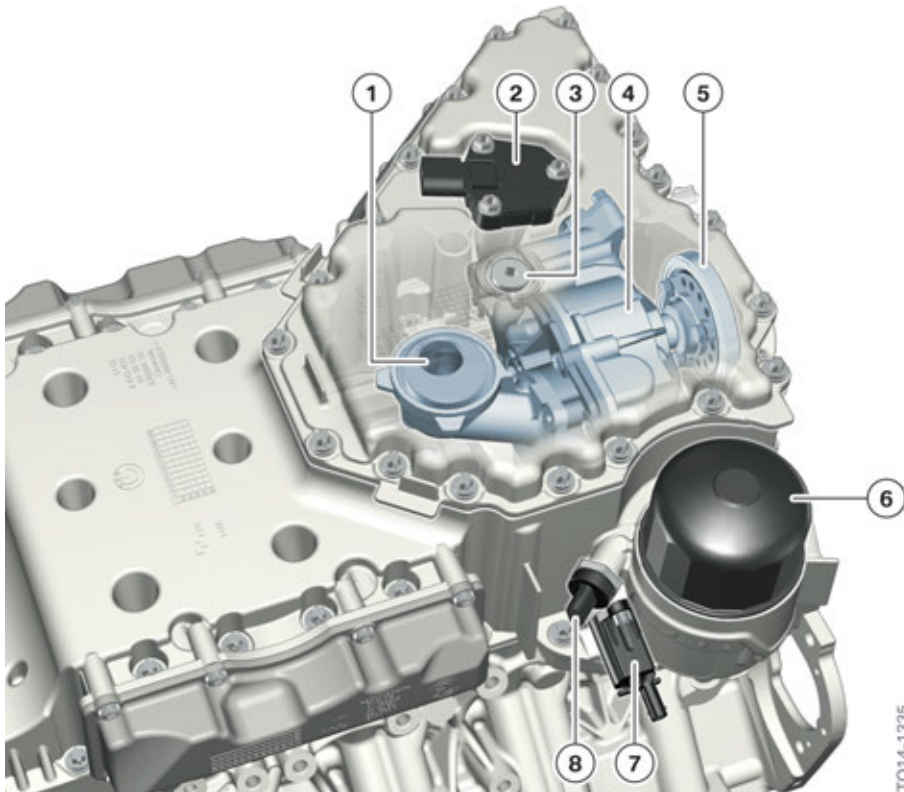

N63TU engine, oil sump with oil pump

Index	Explanation
1	Suction pipe
2	Oil level sensor
3	Oil drain plug
4	Map-controlled pendulum slide cell pump
5	Chain drive of the crankshaft
6	Oil filter cover
7	Map control valve
8	Oil pressure sensor



# N63TU2 Engine

## 2. Engine Mechanical



Like on the N63TU engine, an oil dipstick is installed and can be identified by its protective cap in the engine compartment.

### 2.2. Crankshaft drive

Compared with the N63TU engine, only minor modifications have been made to the crankshaft drive.



N63TU2 engine, crankshaft drive with connecting rod and piston

Index	Explanation
1	Crankshaft
2	Chain gear for oil pump
3	Chain gear for camshafts

# N63TU2 Engine

## 2. Engine Mechanical

### 2.2.1. Crankshaft with bearings

#### Crankshaft

The entire crankshaft of the N63TU2 engine has been taken over from the N63TU engine. It has a stroke of 88.3 mm and is made from C38. It is a forged crankshaft with a hardened surface layer and 6 balance weights.

#### Crankshaft bearings

The crankshaft of the N63TU2 engine is supported by five bearings. The entire crankshaft bearings of the N63TU2 engine have been taken over from the N63TU engine. The two-material thrust bearing is located in the middle at the third bearing position. Robust lead-free two-material bearings are used.

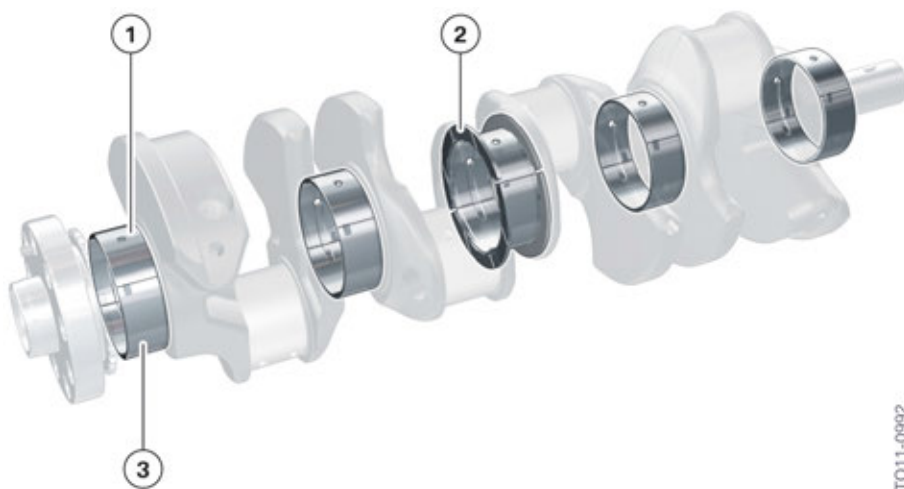

N63TU2 engine, crankshaft bearings

Index	Explanation
1	Upper bearing shell with groove and oil hole
2	Thrust bearing with groove and oil hole
3	Lower bearing shell without groove



The identification markings for the bearings are stamped on the crankcase and on the crankshaft. Refer to the repair instructions if the crankshaft is to be fitted with new bearings.

# N63TU2 Engine

## 2. Engine Mechanical

### 2.2.2. Flywheel

In contrast to the N63TU engine, the flywheel on the N63TU2 has been redeveloped. Thanks to this new design, the number of separate components that make up the flywheel has been reduced from 4 on the N63TU engine to 3 on the N63TU2 engine.

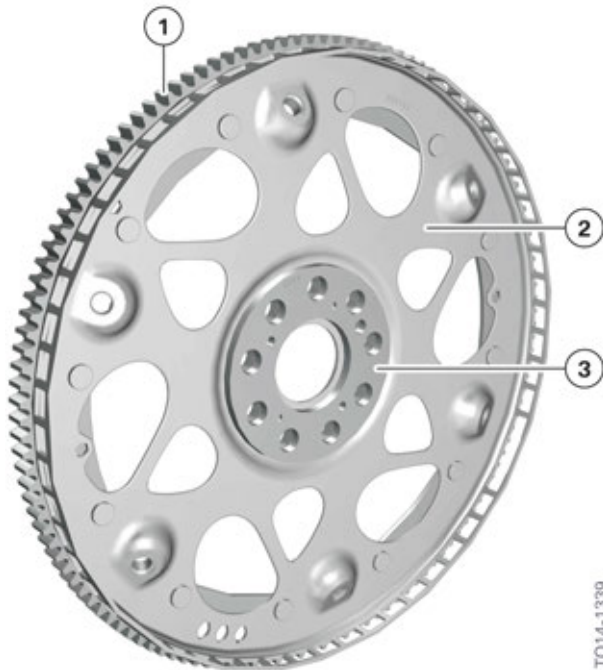

N63TU2 engine, three-part flywheel

Index	Explanation
1	Ring gear for starter motor
2	Carrier plate
3	Drive flange for crankshaft

In addition to optimizing the production process, the weight has also been reduced from 3060 g on the N63TU engine to 2540 g on the N63TU2.



The new three-part flywheel is being integrated into the ongoing standard production of the N63TU engine as well as the N63TU2 engine. The three-part flywheel is backwards-compatible with the N63TU engine.

# N63TU2 Engine

## 2. Engine Mechanical

### 2.2.3. Connecting rod with bearing

#### Connecting rod

The connecting rod on the N63TU2 engine has been taken over from the N63TU engine. It is a cracked forged connecting rod with even pitch. The small connecting rod eye is drilled into the forged, trapezoidal connecting rod head, undergoes precise surface treatment, is hardened and therefore has no bushing. The force acting from the piston via the wrist pin is optimally distributed to the bushing surface.



TO14-1340

N63TU2 engine, cracked connecting rod with even pitch

#### Bearings

The connecting rod bearing shells have no lead and have been changed over from electroplated bearings in the N63TU engine to steel/aluminium/anti-friction coating in the N63TU2 engine. On the connecting rod bearing rod side, a G-411 bearing made of bronze and the red anti-friction coating "IROX" is installed. On the connecting rod bearing cap, an A-370 aluminium bearing is used.

# N63TU2 Engine

## 2. Engine Mechanical

### IROX coating

In order to comply with the increasingly stringent exhaust emission regulations, most combustion engines nowadays are equipped with an automatic engine start-stop function. This has led to a huge increase in starting cycles.

To ensure the engine runs smoothly, it is important that sufficient lubricating oil is supplied to the bearing positions of the crankshaft. If the oil supply can be ensured, solid body contact will not occur between the connecting rod bearing journal and connecting rod bearing shell due to the thin lubricating film.

If the engine is now stopped, it will not be possible for the mechanically driven oil pump to maintain the oil supply. The oil film between the bearing positions flows off. Solid body contact occurs between the connecting rod bearing journal and connecting rod bearing shell. Once the engine is restarted, it takes a certain amount of time for the lubricating film to fully re-establish itself. The connecting rod bearing shell may be subject to wear in this short period. The IROX coating reduces this wear to a minimum.

The IROX-coated bearing shells are only located on the connecting rod side as here the load acts mainly on the bearing shells. The bearing shell caps are equipped with a bearing shell without IROX coating.

The IROX bearings are red due to their special coating.

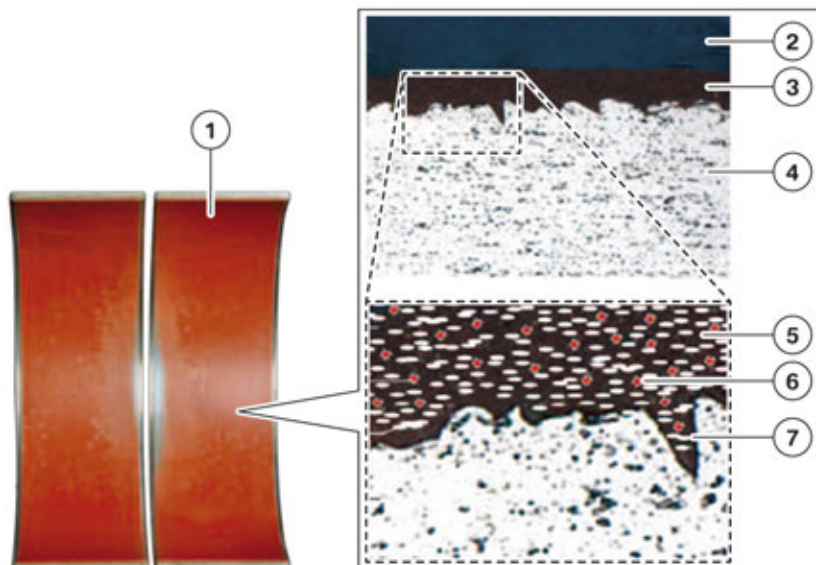

N63TU2 engine, detailed magnification of the IROX coating

TO14-0130

# N63TU2 Engine

## 2. Engine Mechanical

Index	Explanation
1	IROX-coated bearing shell
2	Oil film
3	IROX coating
4	Bearing shell
5	Binding resin
6	Hard particle
7	Solid lubricant

The IROX coating is applied to a conventional bearing shell. It consists of a binding resin matrix made of polyamide-imide with embedded hard particles and solid lubricants. The polyamide-imide ensures, in combination with the hard particles, that the bearing shell surface is so hard that material abrasion is no longer possible. The solid lubricants reduce surface friction and replace the oil film which briefly no longer exists between the bearing shell and the connecting rod bearing journal during the starting phase.

### 2.2.4. Piston with piston rings

On the N63TU2 engine, newly developed cast pistons with a Mahle piston ring package are used. The shape of the piston crown in the N63TU2 engine was modified in order to achieve a compression ratio of 10.5:1 in the N63TU2 as opposed to 10:1 in the N63TU. The piston crown was also adapted to the combustion process, the valve positions and the use of solenoid valve injectors with multiple nozzles in accordance with the N63TU2 engine.

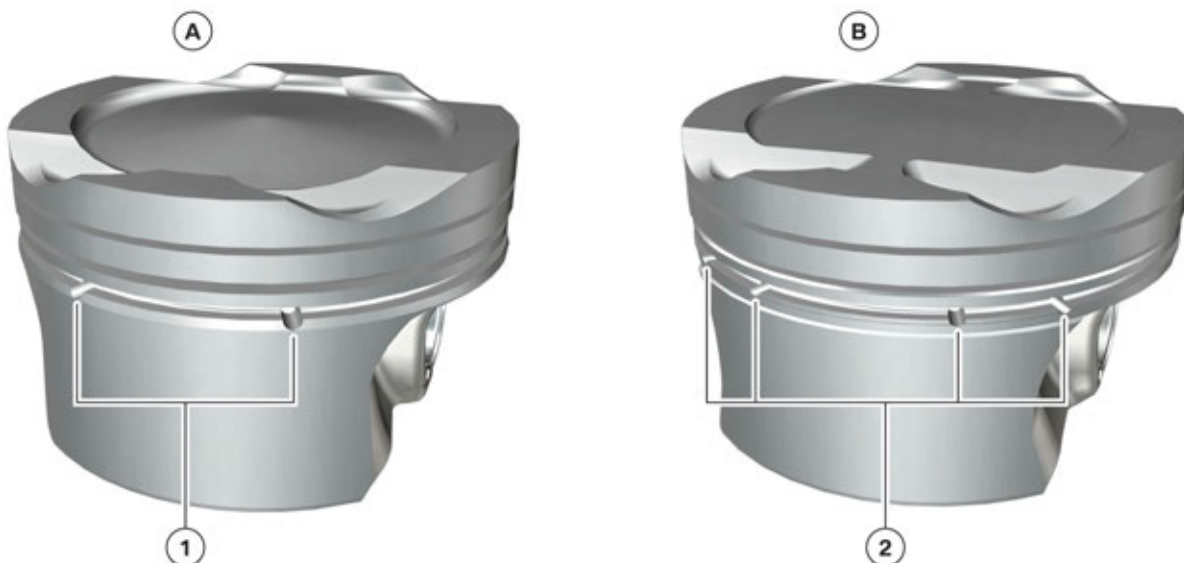

N63TU2 engine, piston comparison

TO14-1341

# N63TU2 Engine

## 2. Engine Mechanical

Index	Explanation
A	N63TU Piston
B	N63TU2 Piston
1	4 oil drains
2	8 oil drains

In order to improve the drainage of oil in the N63TU2 engine, the piston was fitted with an additional oil groove underneath the oil scraper ring groove, as on the N55 engine. Together with the 8 oil drains in the piston skirt, the additional oil groove facilitates the drainage of the oil pushed down by the oil scraper ring when the piston moves down. This prevents the oil from being carried past the piston rings, in particular when the engine is in coasting overrun mode (during which a vacuum is generated in the combustion chamber).

In terms of the piston rings, the ring package from Mahle has been taken over from the N63TU engine. Only the width of the oil scraper ring in the N63TU2 engine was reduced from 2 mm to 1.8 mm.

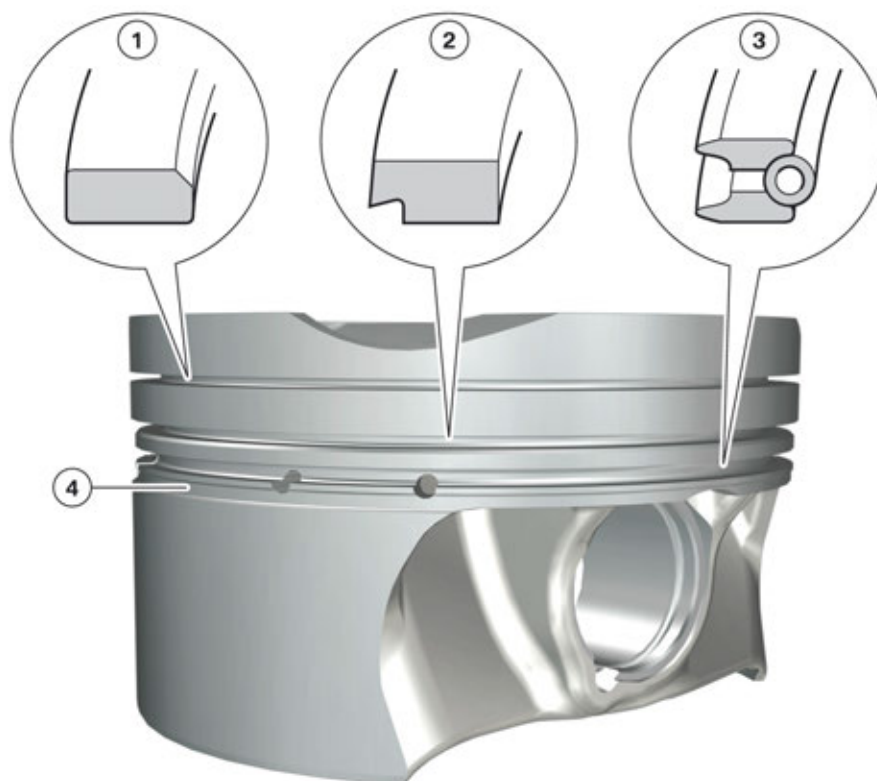

N63TU2 engine, cast piston with piston rings

Index	Explanation
1	Plain rectangular compression ring
2	Taper faced piston ring (NM-ring)
3	Oil scraper ring with spiral expander (DSF-ring)
4	Additional oil groove

# N63TU2 Engine

## 2. Engine Mechanical

### 2.3. Camshaft drive/chain drive

The entire chain drive for driving the camshafts on the N63TU2 engine has been taken over from the N63TU engine. As on the N63TU engine, a toothed sleeve-type chain with 142 elements is used per cylinder bank for driving the assembled camshafts. This is supplied with oil via the oil spray nozzle in the chain tensioner. Tensioning rail, guide and slide rails are now different parts for both banks. The tensioning rail with an integrated thrust piece is made completely from plastic.

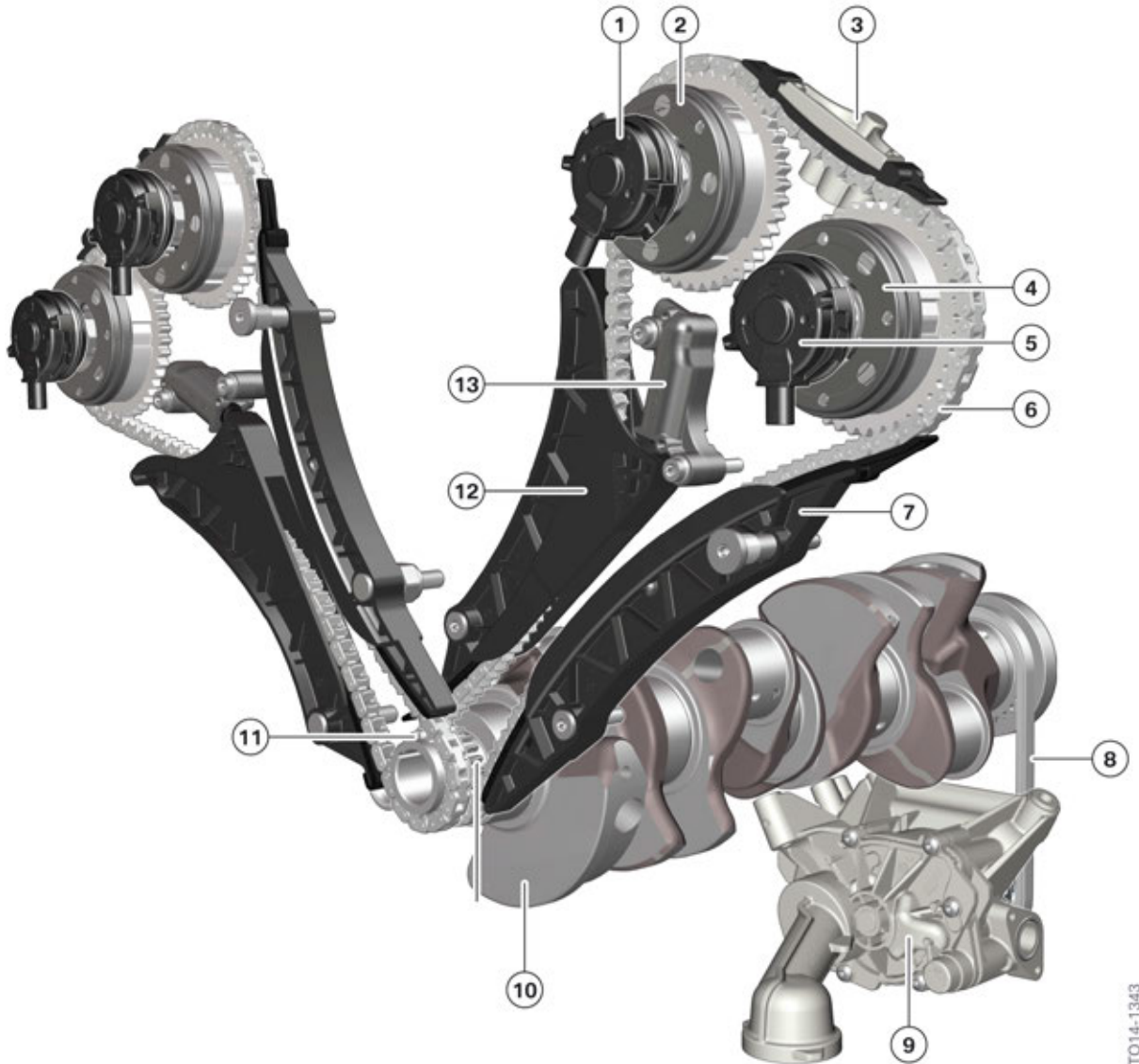

TO14-1343

N63TU2 engine, chain drive



# N63TU2 Engine

## 2. Engine Mechanical

Index	Explanation
1	VANOS solenoid actuator, exhaust side
2	VANOS unit, exhaust side
3	Slide rail with oil supply
4	VANOS unit, intake side
5	VANOS solenoid actuator, intake side
6	Sleeve-type chain for camshaft drive
7	Slide rail
8	Sleeve-type chain for oil pump drive
9	Characteristic map-controlled oil pump
10	Crankshaft
11	Crankshaft gear
12	Tensioning rail
13	Chain tensioner

### 2.4. Valve gear

#### 2.4.1. Design

In the N63TU2 engine, in addition to the double VANOS the fully variable Valvetronic is also used, as in the N63TU engine. In contrast to the N63TU engine (in which the VANOS solenoid valves were integrated into the cylinder head), on the N63TU2 engine the central VANOS solenoid valve is installed (already known from the N20 engine and the B Gasoline engines in a modular design). Thanks to these measures, the design of the cylinder head was simplified by removing the oil-carrying ducts running to the VANOS control.

The rest of the valve gear essentially consists of the familiar components from the N63TU engine.

# N63TU2 Engine

## 2. Engine Mechanical

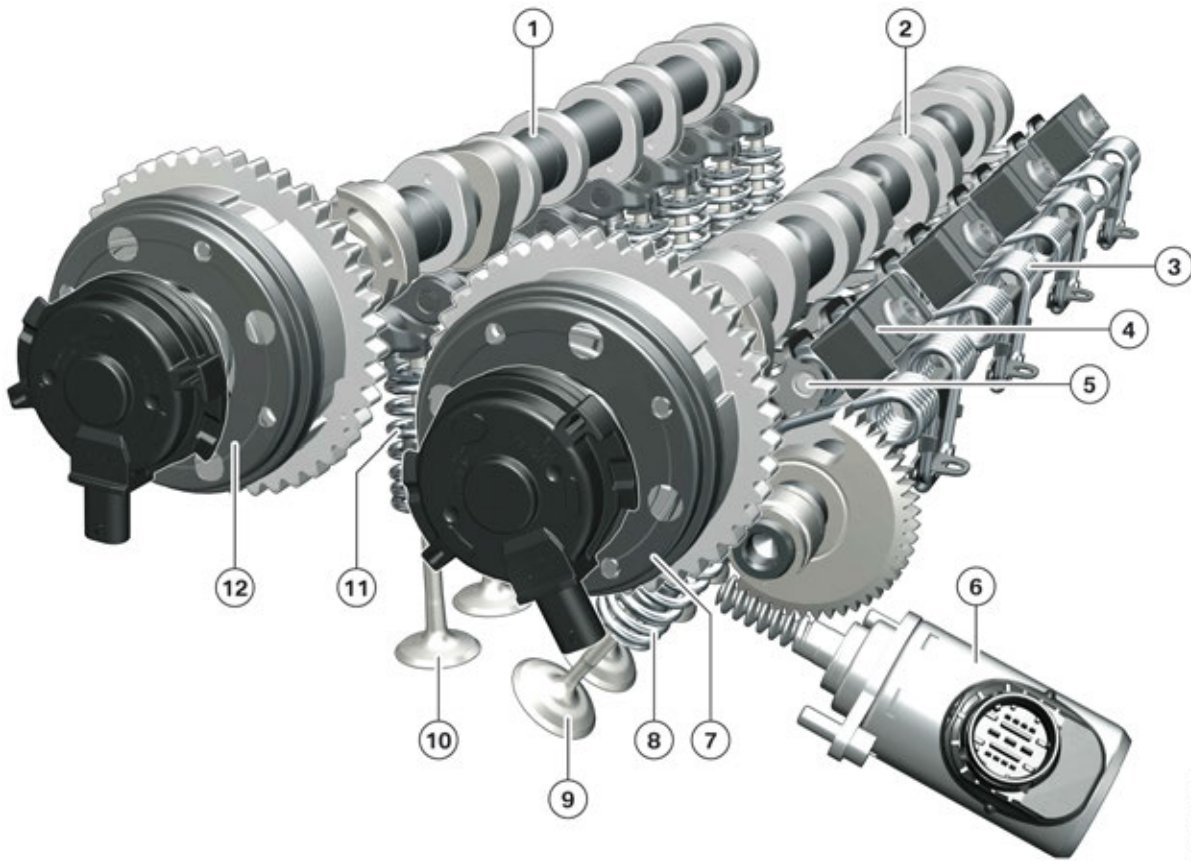

TO14-1344

N63TU2 engine, valve gear

Index	Explanation
1	Exhaust camshaft
2	Intake camshaft
3	Torsion spring
4	Gate/guide block
5	Intermediate lever
6	Valvetronic servomotor
7	VANOS intake side
8	Valve spring, intake valve
9	Intake valve
10	Exhaust valve
11	Valve spring, exhaust valve
12	VANOS exhaust side

# N63TU2 Engine

## 2. Engine Mechanical

### Camshafts

The N63TU2 engine possesses the known camshafts in a lightweight construction. All cams are forced onto knurled points. The camshafts have a mounting for the central VANOS units and modified timing on the exhaust side compared with the N63TU engine.

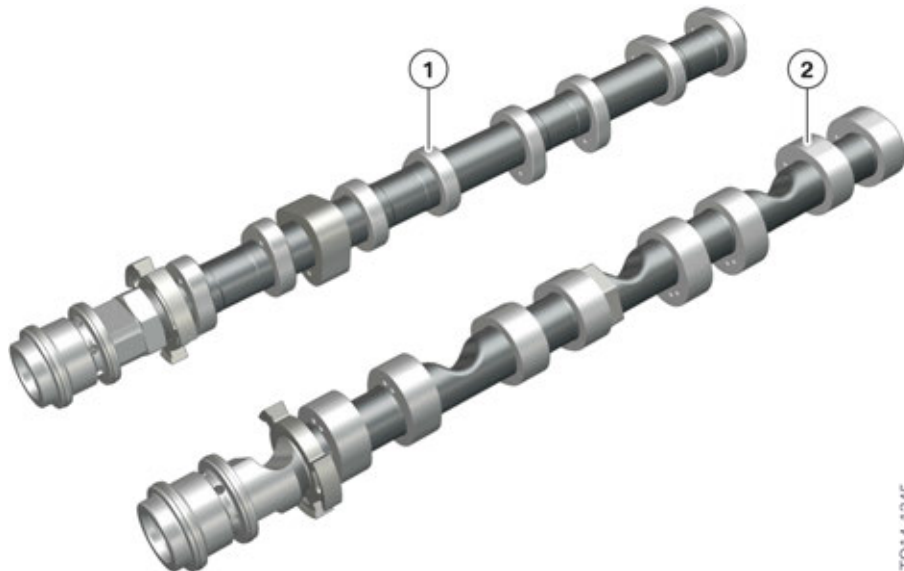

TO14-1345

N63TU2 engine, built-up camshafts

Index	Explanation
1	Exhaust camshaft, cylinder bank 2
2	Intake camshaft, cylinder bank 2

# N63TU2 Engine

## 2. Engine Mechanical

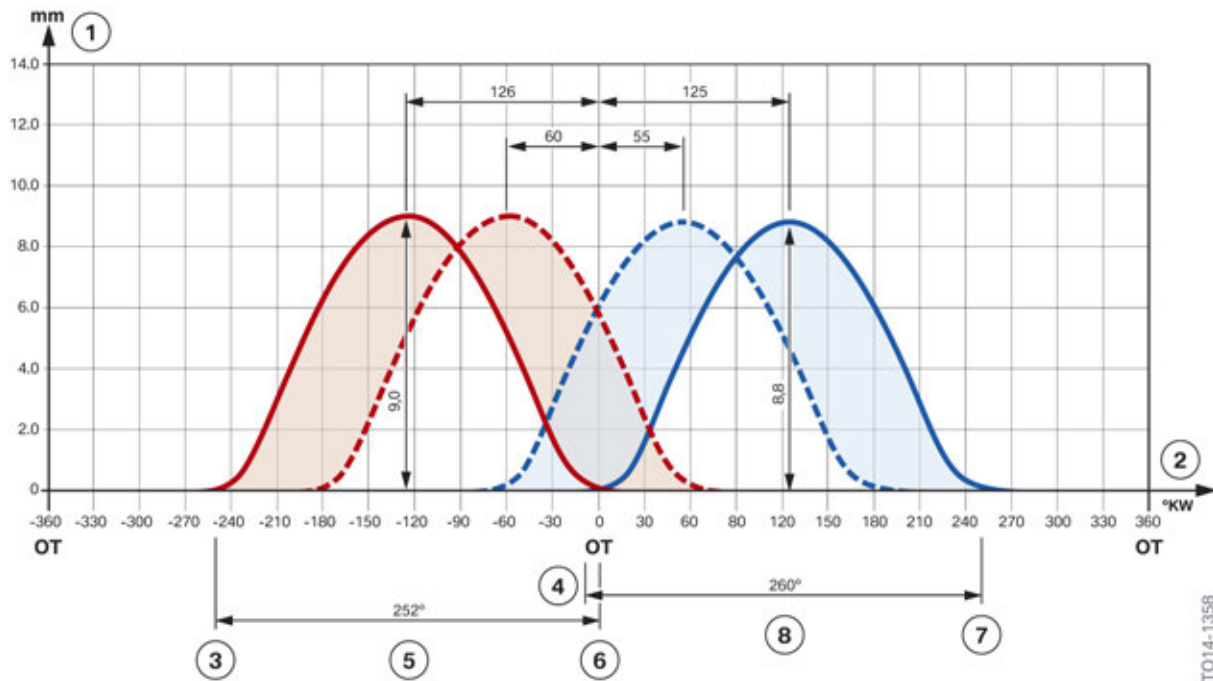

N63TU2 engine, valve cams

Index	Explanation
1	Valve lift [mm]
2	Crankshaft degrees [°KW]
3	Exhaust valve open
4	Intake valve open
5	Opening period of exhaust valve
6	Exhaust valve closes
7	Intake valve closes
8	Opening period of intake valve

As the exhaust valves are opened for longer, the high residual temperature in the exhaust gas is used to heat up the catalytic converters faster. As the temperature of the catalytic converters increases, the VANOS is used to set a later timing for the exhaust side.

### Technical data of valve gear

		N63B44O1	N63B44O2
Intake valve dia. / Shaft diameter	[mm]	33.2/6	33.2/6
Exhaust valve dia./stem dia.	[mm]	29/6	29/6
Maximum valve lift, intake/exhaust valve	[mm]	8.8/9.0	8.8/9.0
VANOS adjustment range, intake	[cranksh degrees]	70	70

# N63TU2 Engine

## 2. Engine Mechanical

		N63B44O1	N63B44O2
VANOS adjustment range, exhaust	[cranksh degrees]	55	66
Spread, intake camshaft	[cranksh degrees]	55 – 125	55 – 125
Spread, exhaust camshaft	[cranksh degrees]	60 – 115	60 – 126
Opening period, intake camshaft	[cranksh degrees]	260	260
Opening period, exhaust camshaft	[cranksh degrees]	252	252

### Intake and exhaust valves

The intake and exhaust valves both have a shaft diameter of 6 mm. In contrast to the N63TU engine, the valve stems on the N63TU2 engine are chrome-plated. The exhaust valves are hollow and filled with natrium (which is Sodium). This results in improved and quicker heat dissipation.

### Valve stem guides

The N63TU2 engine has high-temperature-resistant valve stem guides made of brass.

### 2.4.2. Valvetronic



The Valvetronic comprises fully variable valve lift control and variable camshaft control (double VANOS), which makes the closing time of the intake valve freely selectable.

Valve lift control is performed on the intake side, while camshaft control is performed on both the intake and exhaust sides.

Throttle-free load control is only possible if:

The lift of the intake valve and the adjustment of the intake and exhaust camshafts are variably controllable.

Result:

The opening and closing times and the opening period and the lift of the intake valve is variable.

### VANOS

The valve overlap times have a significant impact on the characteristics of a gasoline engine. An engine with a small valve overlap therefore tends to have a high maximum torque at low engine speeds, but the maximum power that can be achieved at high engine speeds is low. The maximum power achieved with a large valve overlap on the other hand is higher, but this is at the expense of the torque at low engine speeds.

# N63TU2 Engine

## 2. Engine Mechanical

The VANOS provides a solution. It makes a high torque possible in the low and medium engine speed range and a high maximum power in the higher engine speed ranges. A further benefit of the VANOS is internal EGR. This reduces the emission of harmful nitrogen oxides (NOx), particularly in the partial load range. The following is also achieved:

- Faster heating up of catalytic converter
- Lower pollutant emissions during cold start
- Reduction in consumption.

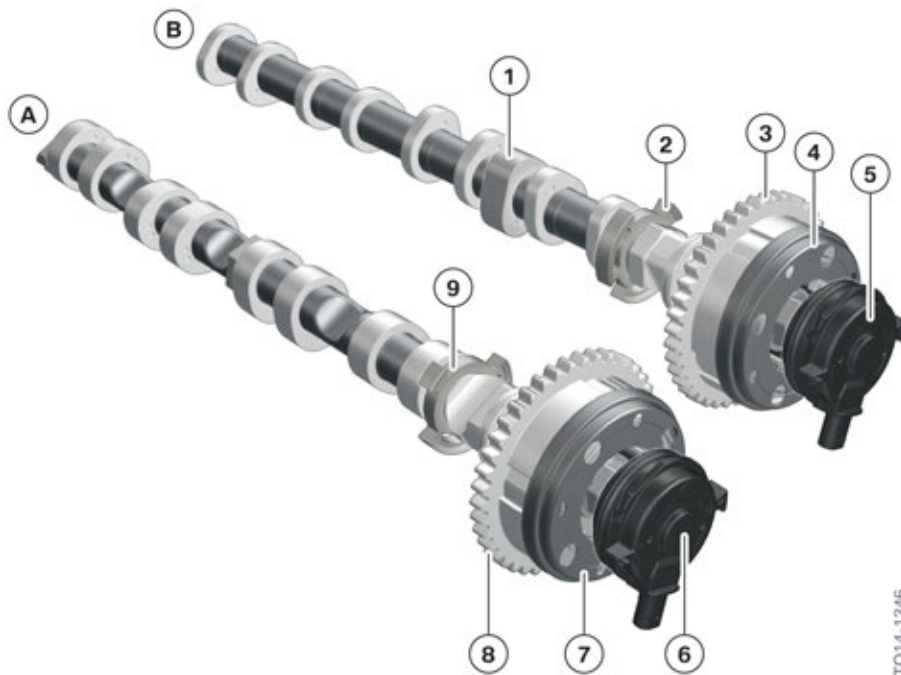

N63TU2 engine, double VANOS

Index	Explanation
A	Intake camshaft
B	Exhaust camshaft
1	Triple cam for high pressure pump drive system
2	Increment wheel, exhaust camshaft
3	Exhaust camshaft sprocket
4	VANOS unit, exhaust side
5	VANOS solenoid actuator, exhaust
6	VANOS solenoid actuator, intake
7	VANOS unit, intake side
8	Intake camshaft sprocket
9	Increment wheel, intake camshaft

# N63TU2 Engine

## 2. Engine Mechanical

### Reason for using the double VANOS

The advantages of a Valvetronic are lower charge cycle losses and therefore potential for reducing fuel consumption by adopting an appropriate driving style. However, in contrast to throttle valve-controlled systems, Valvetronic cannot reduce charge-cycle losses in the full load range.

### VANOS unit

With older VANOS systems, such as those used in the N63TU and N55 engines, the VANOS adjusters were controlled by separate VANOS solenoid valves integrated into oil ducts in the cylinder head.

The oil ducts in the cylinder head are reduced and the adjustment speed is increased by using a VANOS solenoid valve unit and a mechanical VANOS central valve, which is located inside the VANOS unit.

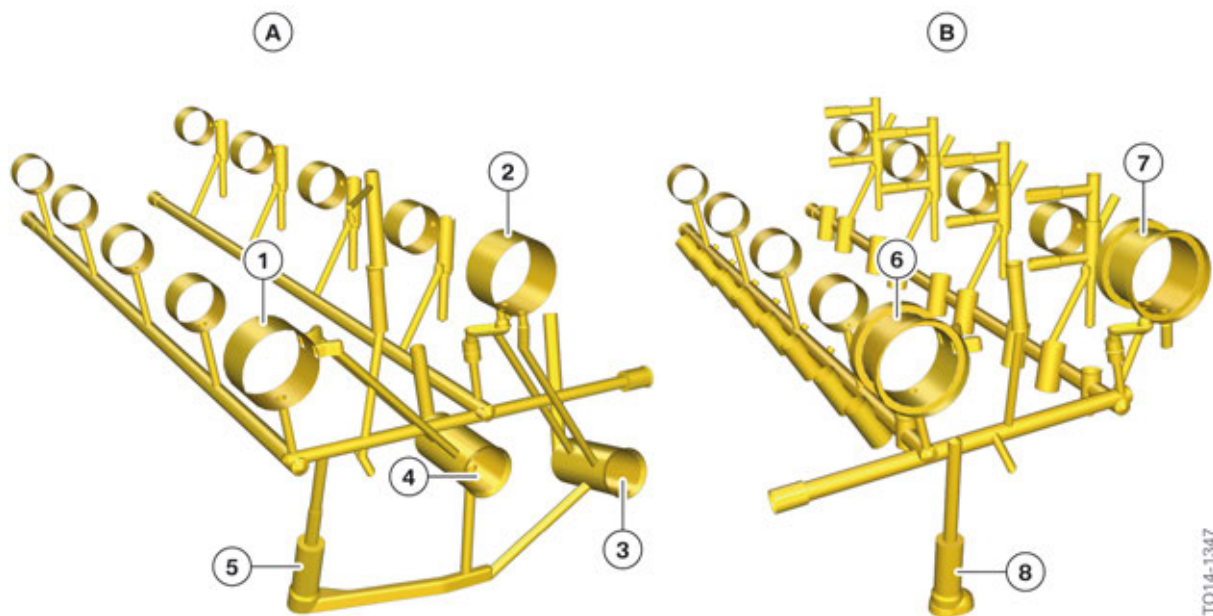

N63TU2 engine, VANOS oil ducts

Index	Explanation
A	Oil ducts for VANOS control, N63TU engine
B	Oil ducts for VANOS control, N63TU2 engine
1	VANOS oil duct, intake
2	VANOS oil duct, exhaust
3	VANOS solenoid valve in oil duct, exhaust
4	VANOS solenoid valve in oil duct, intake
5	Oil duct non-return valve
6	VANOS adjuster in oil duct, exhaust
7	VANOS adjuster in oil duct, intake
8	Oil duct non-return valve

TO14-1347

# N63TU2 Engine

## 2. Engine Mechanical

On the intake side the basic VANOS position is "late", adjustment is for an "earlier" setting.

On the exhaust side the basic VANOS position is "early", adjustment is for a "late" setting .

The adjustment process of the VANOS adjusters is shown in the following graphics using the example of the intake side.

The following graphic shows the oil ducts in the VANOS unit.

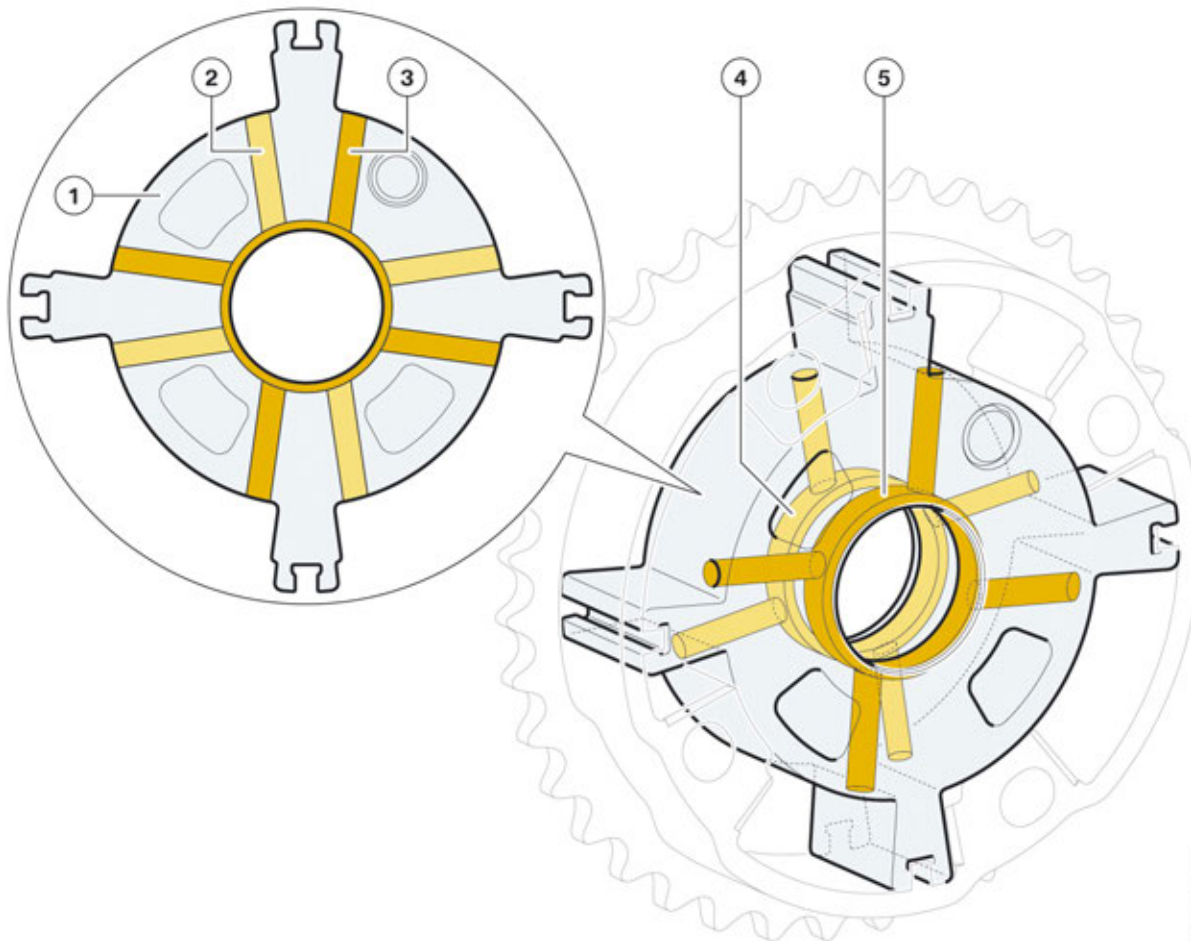

N63TU2 engine, VANOS unit, intake camshaft

Index	Explanation
1	Rotor
2	Oil duct for timing advance
3	Oil duct for timing retardation
4	Oil duct for timing advance
5	Oil duct for timing retardation

The intake camshaft can be "advanced" with the ducts shaded light yellow; the VANOS unit can be "retarded" with the ducts shaded dark yellow.



# N63TU2 Engine

## 2. Engine Mechanical

The locking pin ensures that the VANOS adjuster adopts a clear, locked position when depressurized. The locking spring ensures the unit is locked by continuously pushing the locking pin into the locked position when the actuator is de-energized. The VANOS unit is blocked in this condition. The timing can be adjusted in this way. This is important when the engine is started to ensure exact timing. The oil pressure which is present for timing advance simultaneously unlocks the locking pin via oil ducts in the VANOS unit. If the camshaft is to be “advanced”, the locking pin is then forced by the applied oil pressure against the locking spring towards the cartridge and the locking cover is released for VANOS adjustment.

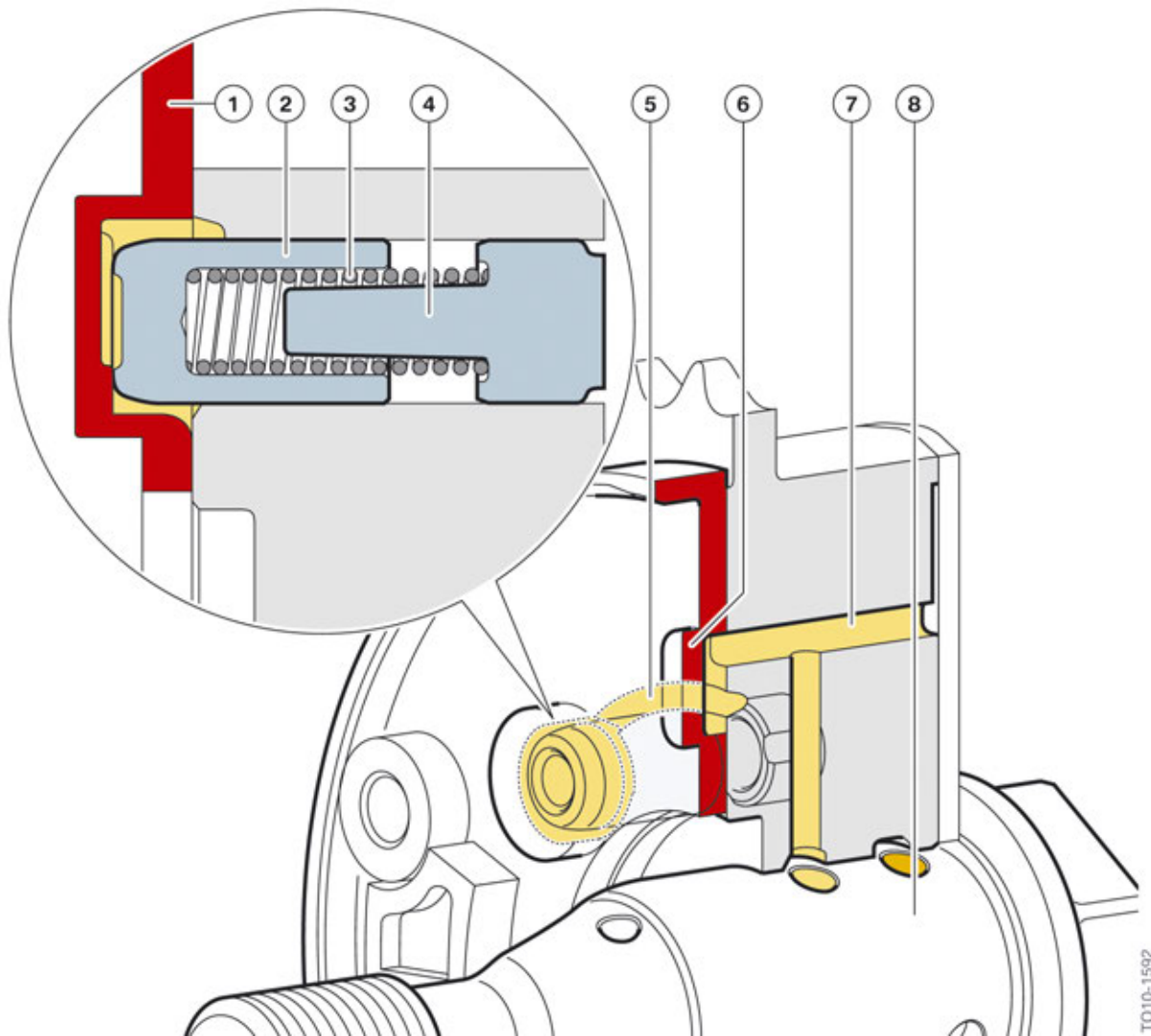

N63TU2 engine, locking pin

Index	Explanation
1	Locking cover
2	Locking pin
3	Locking spring
4	Cartridge

# N63TU2 Engine

## 2. Engine Mechanical

Index	Explanation
5	Oil duct
6	Locking cover
7	Oil duct
8	VANOS central valve

The VANOS unit is secured to the camshaft by the VANOS central valve. The oil passages rate into the VANOS adjuster is simultaneously controlled by this VANOS central valve. The system is actuated by a solenoid actuator, which presses its own piston against the piston (4) of the VANOS central valve, thereby pressing it against the spring (8). The oil passages rate is controlled via the piston (4) and the bore holes in the sleeve (5).

The following graphic shows the oil passages rate in the VANOS central valve at the intake camshaft for controlling the camshaft adjustment to achieve a "late" setting when the solenoid actuator is de-energized. When the solenoid actuator is de-energized, the piston (4) is moved by the spring into the "extended" setting. This causes oil to passages from the main oil duct into the bore hole to the VANOS oil duct (late setting).

The small graphic shows the oil passages from the VANOS adjuster into the cylinder head when the engine is stopped.

# N63TU2 Engine

## 2. Engine Mechanical

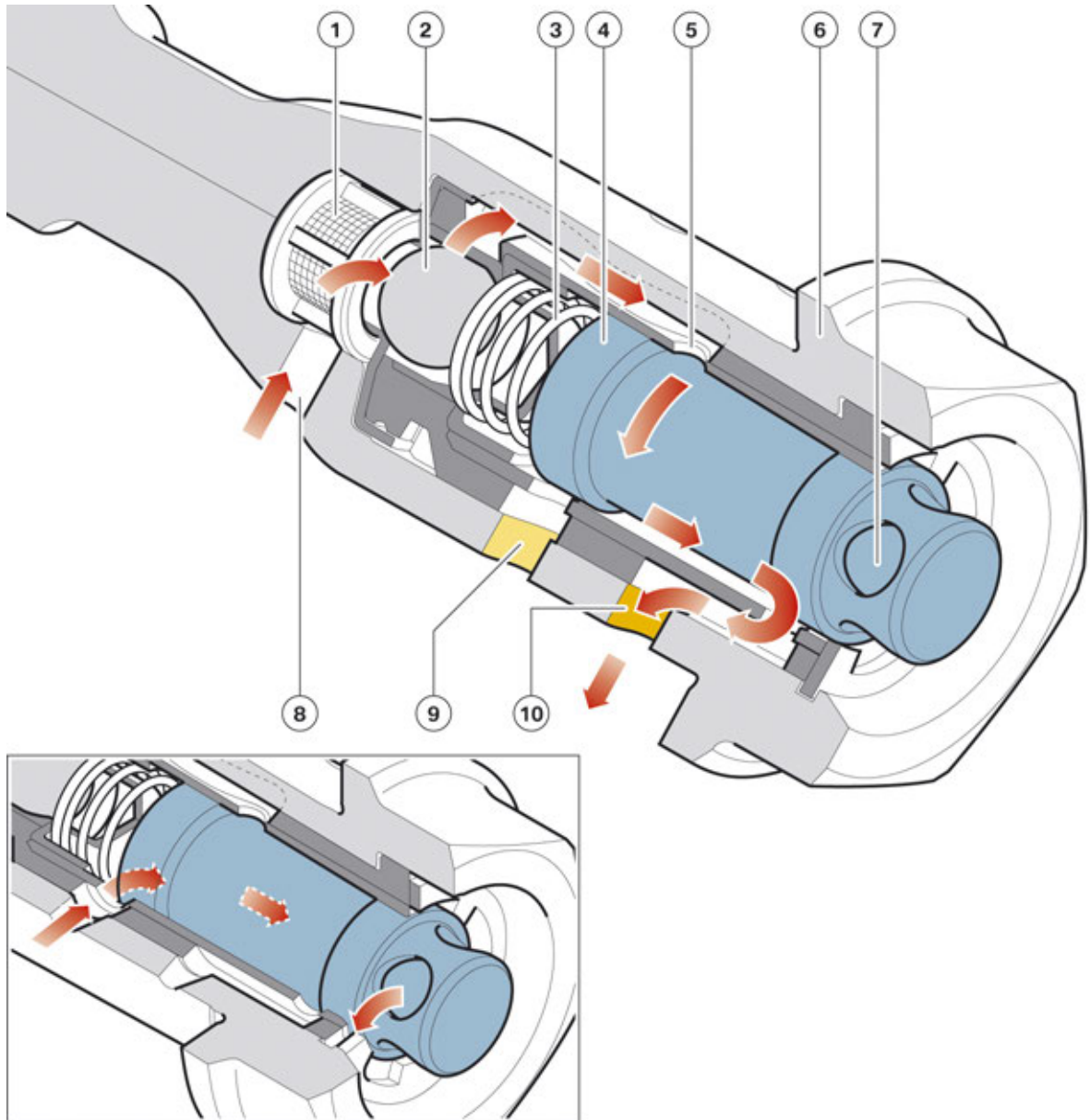

N63TU2 engine, VANOS central valve, intake camshaft

TO10-1593

Index	Explanation
1	Filter
2	Ball
3	Spring
4	Piston
5	Sleeve
6	Housing

# N63TU2 Engine

## 2. Engine Mechanical

Index	Explanation
7	Opening in plunger
8	Oil supply from main oil duct
9	Bore to oil duct in VANOS (timing advance)
10	Bore to oil duct in VANOS (timing retardation)

The following graphic shows the oil passages in the VANOS central valve at the intake camshaft for controlling the camshaft adjustment to achieve an "early" setting when the solenoid actuator is energized. When the solenoid actuator is energized, the piston (4) is moved against the spring into a "retracted" setting. This causes oil to pass from the main oil duct into the bore hole to the VANOS oil duct (early setting). The oil in the chambers for the VANOS late setting can pass into the cylinder head via the gap created between the piston (4) and the housing (6).

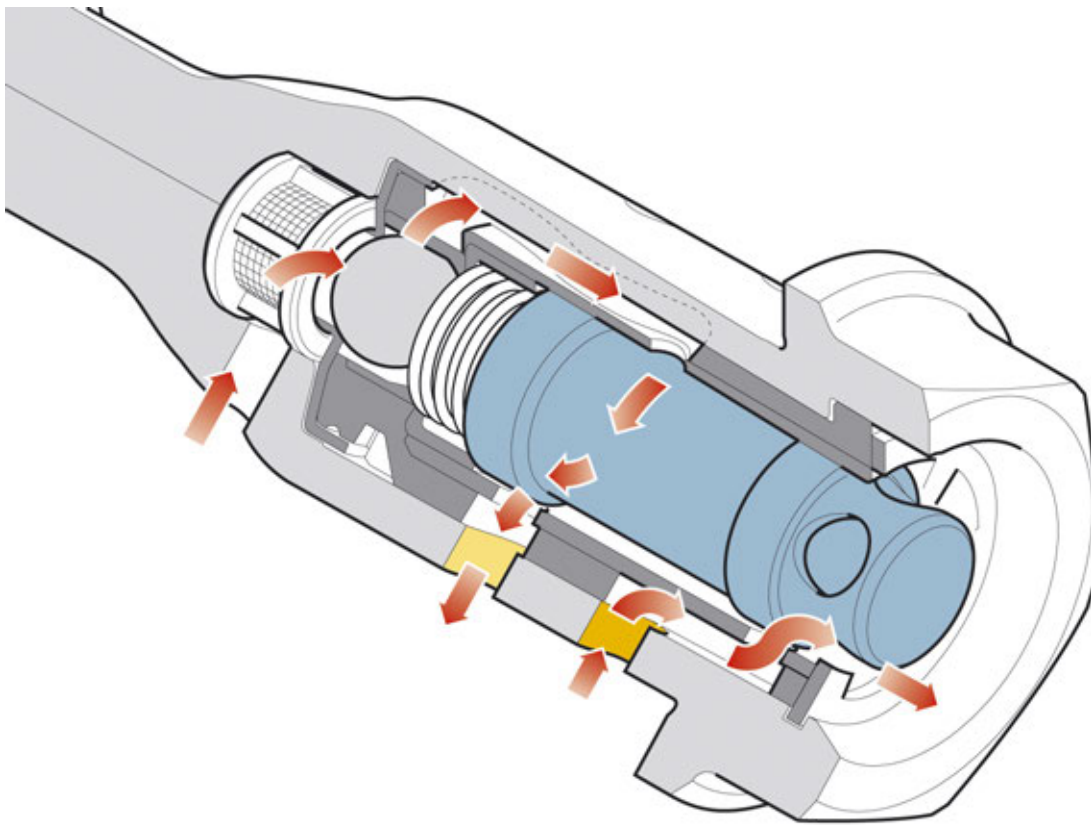

N63TU2 engine, VANOS central valve, intake camshaft

### VANOS adjustment on intake side

On the intake side, when energizing the solenoid actuator the VANOS adjuster is adjusted to achieve an "early" setting. The counter-adjustment to achieve a "late" setting is performed when the solenoid actuator is de-energized.

# N63TU2 Engine

## 2. Engine Mechanical

### **VANOS adjustment on exhaust side**

On the exhaust side, when energizing the solenoid actuator the VANOS adjuster is adjusted to achieve a "late" setting. The counter-adjustment to achieve an "early" setting is performed when the solenoid actuator is de-energized.

### **Valve lift control**

On the N63TU2 engine, the Valvetronic system has been taken over from the N63TU engine with the following modifications.

- Sliding blocks with only one screw connection.
- Smaller and more powerful Valvetronic servomotor, taken over from modular engines.

As can be seen in the following diagram, the Valvetronic servomotor is attached at the intake side to the cylinder head. The eccentric shaft sensor is integrated in the Valvetronic servomotor.

The Valvetronic III system is used – this supports masking and phasing and is already used on the N55 and N63TU engines. For more information on masking and phasing, please refer to the Technical Reference manual ST501 Engine Technology.

The roller cam follower of the intake side and the intermediate lever are made from sheet metal and divided into various classes. This can be seen on the punched-on numbers.

# N63TU2 Engine

## 2. Engine Mechanical

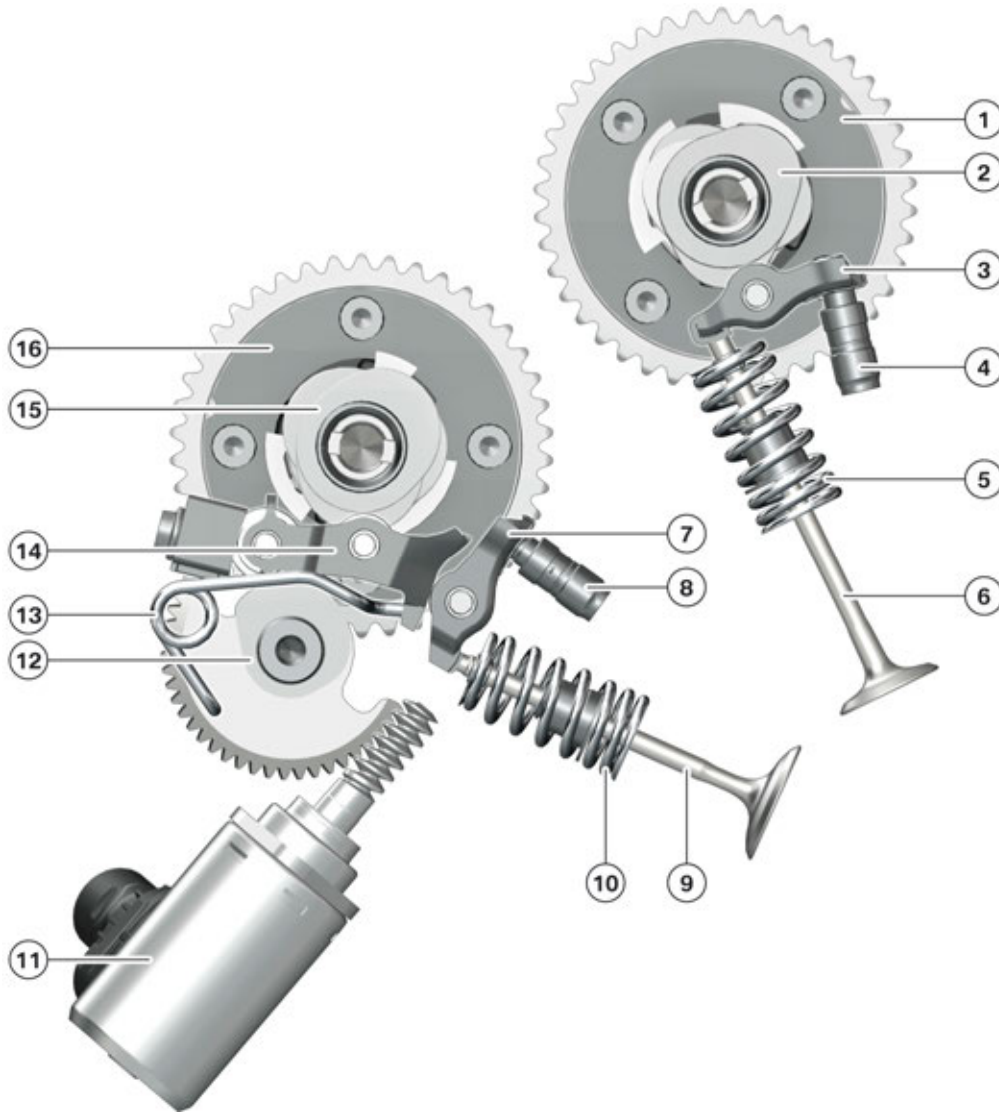

TO14-134B

N63TU2 engine, valve lift control

Index	Explanation
1	VANOS exhaust side
2	Exhaust camshaft
3	Roller cam follower
4	Hydraulic valve clearance compensation HVCC
5	Valve spring on exhaust side
6	Exhaust valve
7	Roller cam follower
8	Hydraulic valve clearance compensation HVCC
9	Intake valve

# N63TU2 Engine

## 2. Engine Mechanical

<b>Index</b>	<b>Explanation</b>
10	Valve spring on intake side
11	Valvetronic servomotor
12	Eccentric shaft
13	Spring
14	Intermediate lever
15	Intake camshaft
16	VANOS intake side

# N63TU2 Engine

## 2. Engine Mechanical

### 2.5. Belt drive

The design of the belt drive was taken over from the N63TU. The belt pulley of the crankshaft is new and made from high-strength plastic. The belt level was moved forwards by 20 mm. As there is no power steering pump, the air conditioning compressor is installed on the right of the engine. The belt drive consists of the alternator, coolant pump and air conditioning compressor. The belt drive is operated with a tensioning pulley with torsion spring tensioner.

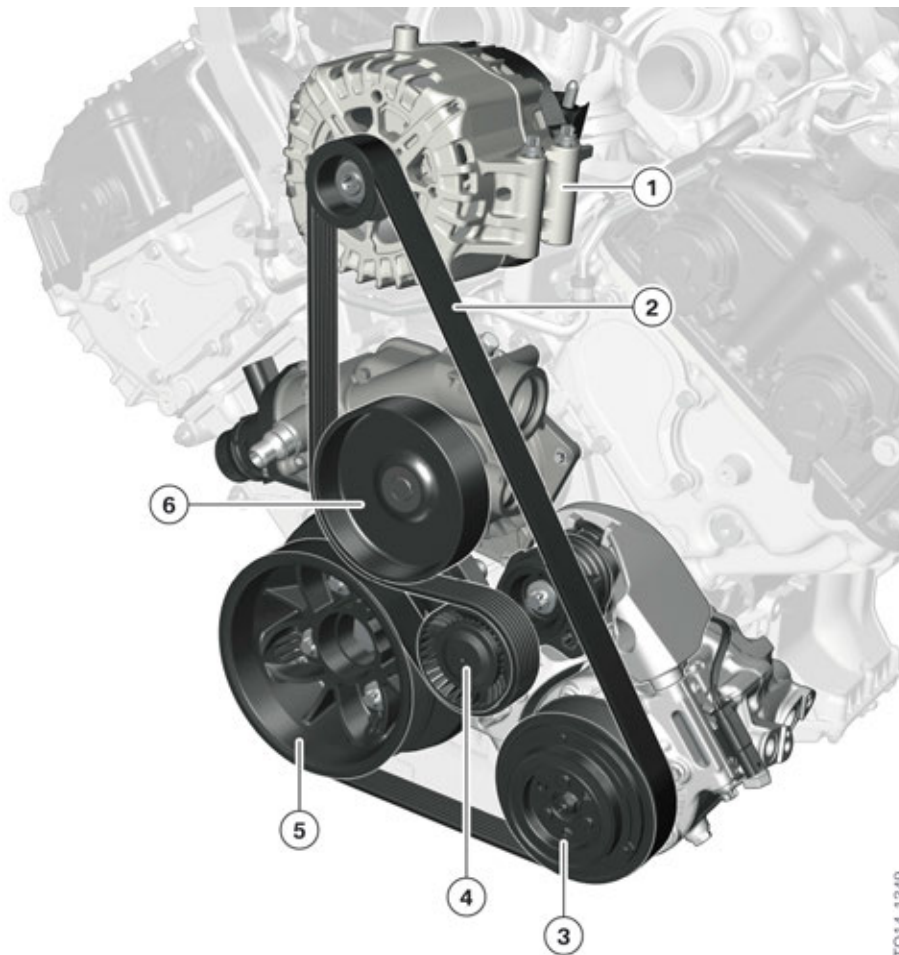

TO14-1349

N63TU2 engine, belt drive

Index	Explanation
1	Alternator
2	Belt
3	Belt pulley, A/C compressor
4	Belt tensioner
5	Belt pulley, crankshaft
6	Coolant pump belt pulley

The seven-rib drive belt and the belt tensioner have been taken over from the N63TU.



# N63TU2 Engine

## 2. Engine Mechanical

### 2.6. SynTAK (synergy thermo-acoustic capsule)

On the N63TU2 engine, "SynTAK" covers are being used for the first time. They are located on the left and right long sides of the cylinder heads and the crankcase.

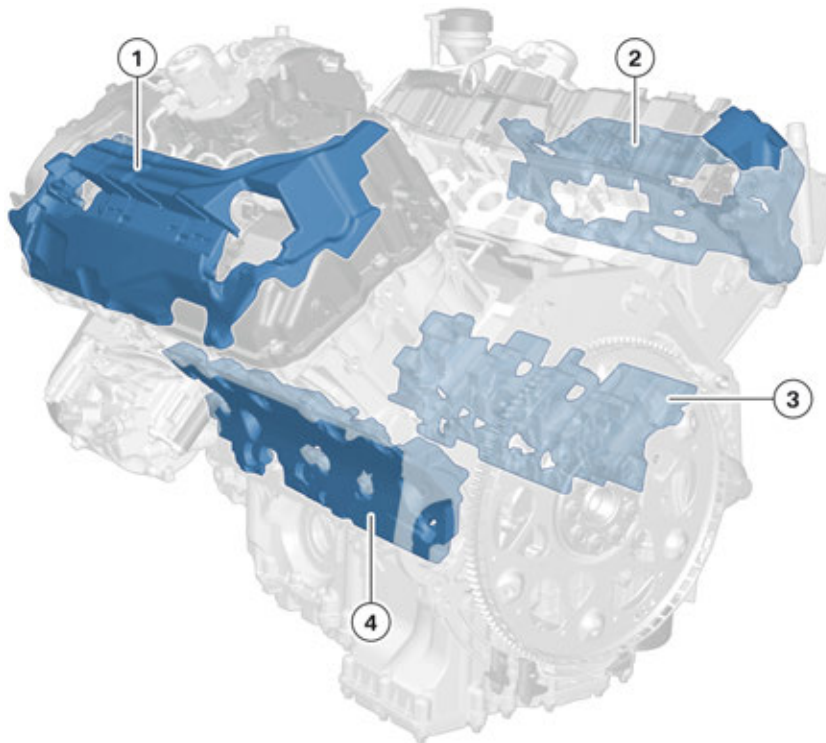

TO14-1350

N63TU2 engine, synergy thermo-acoustic capsule

Index	Explanation
1	SynTAK cover, cylinder head cover, bank 2
2	SynTAK cover, cylinder head cover, bank 1
3	SynTAK cover, crankcase, bank 1
4	SynTAK cover, crankcase, bank 2

The SynTAK system provides acoustic insulation against engine noises for critical acoustic vibrations between 0.5–2 kHz. It also ensures that heat is retained in different operating conditions, such as when the automatic engine start-stop function (MSA) stops the engine or if the engine is switched off for a relatively long period. In some cases it is also responsible for the cable routing for the actuators and sensor system used in the N63TU2 engine.

# N63TU2 Engine

## 3. Oil Supply

### 3.1. Overview

The following graphics provide an overview of the oil supply and show the hydraulic circuit diagram and the actual layout of the oil ducts in the engine.

#### 3.1.1. Hydraulic circuit diagram

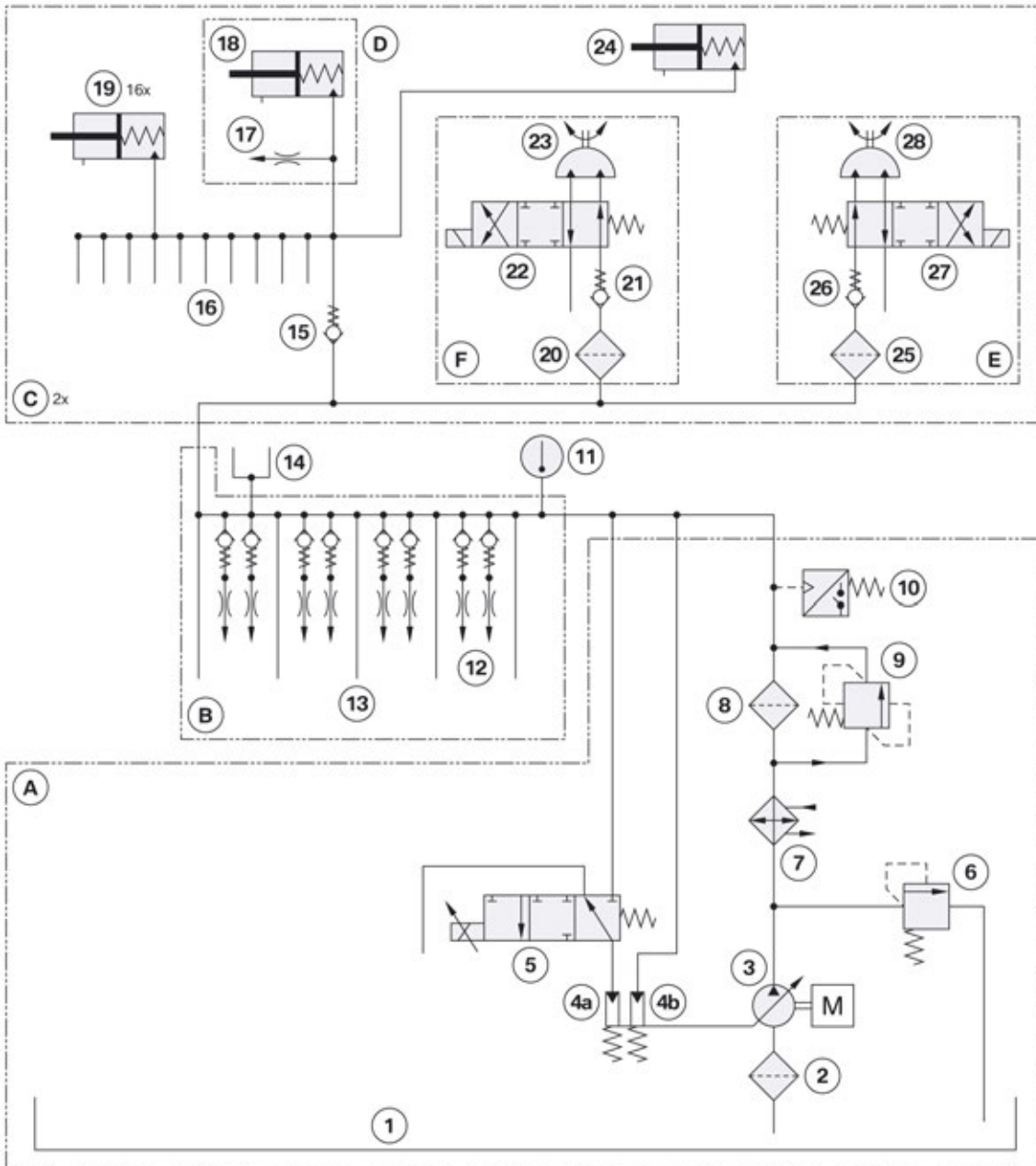

TO14-1355

N63TU2 engine, hydraulic circuit diagram

# N63TU2 Engine

## 3. Oil Supply

Index	Explanation
A	Oil sump
B	Crankcase
C	Cylinder head 2 x
D	Chain tensioner
E	VANOS valve, intake
F	VANOS valve, exhaust
1	Oil sump
2	Strainer
3	Characteristic map-controlled pendulum slide cell pump
4a	Map-controlled control chamber (normal operation)
4b	Second-level control chamber (emergency operation)
5	Map control valve
6	Pressure-limiting valve
7	Engine oil-to-coolant heat exchanger
8	Oil filter
9	Filter bypass valve
10	Oil pressure sensor
11	Oil temperature sensor
12	Oil spray nozzles for piston crown cooling
13	Lubrication point on crankshaft main bearing
14	Lubrication points on exhaust turbocharger
15	Non-return valve, cylinder head
16	Lubrication points on camshaft bearing
17	Oil spray nozzle for timing chain
18	Chain tensioner
19	Hydraulic valve clearance compensating elements (32 x)
20	Strainer
21	Non-return valve
22	VANOS solenoid valve
23	Swivel motor
24	Slide rail lubrication
25	Strainer
26	Non-return valve
27	VANOS solenoid valve
28	Swivel motor

# N63TU2 Engine

## 3. Oil Supply

### 3.2. Oil pump and pressure control

The N63TU engine has a volume-passages-controlled pendulum slide cell pump. In the N63TU2, this is supplemented by the familiar characteristic map control from other BMW engines.

The volume-passages-controlled pendulum slide pump (supplemented by the characteristic map control) is driven at the rear by the crankshaft via a sleeve-type chain.

The actual oil pressure is recorded via an oil pressure sensor and forwarded to the Digital Motor Electronics (DME). The Digital Motor Electronics (DME) performs a target/actual comparison based on the stored characteristic maps. The map-controlled valve is activated by means of a pulse-width modulated signal until the nominal pressure stored in the characteristic map has been reached. During this process, the delivery rate of the oil pump varies according to the oil pressure in the oil duct to the map-controlled control chamber. However, the main function of the volume-passages-controlled pendulum slide cell pump is identical to the existing pendulum slide cell pump.

Information on the operating principle of a volume-passages-controlled oil pump can be found in the Training Reference Manual ST1116 "N63 Engine".

#### 3.2.1. Intake neck

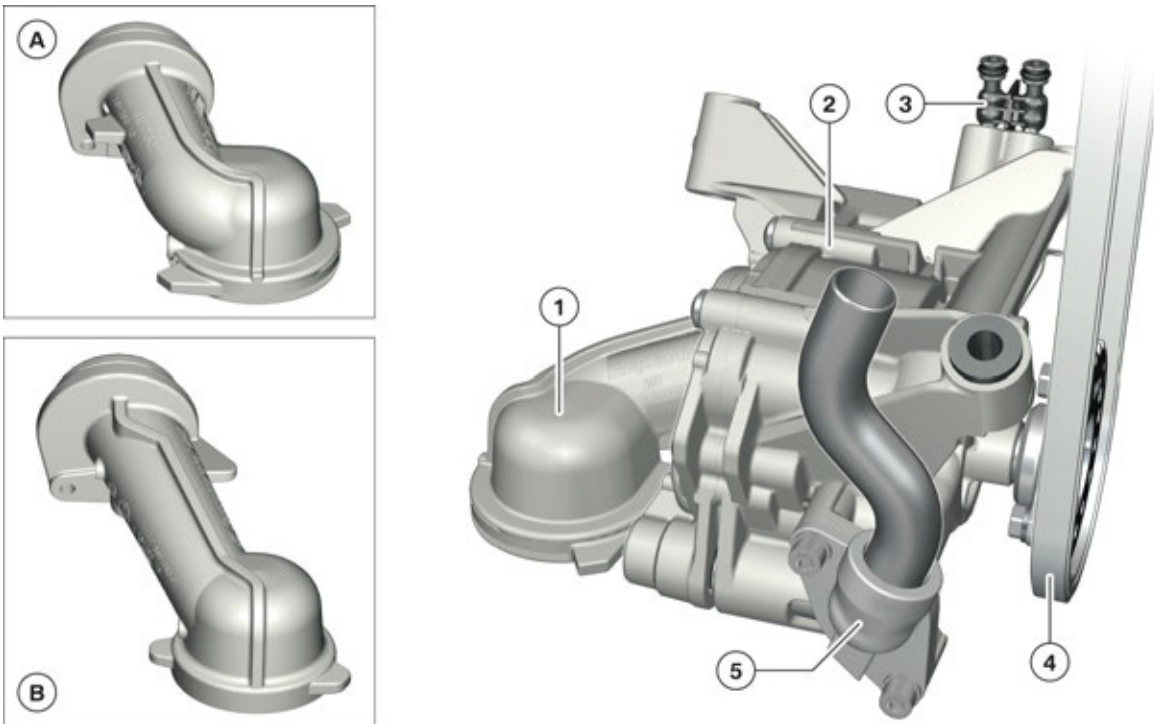

N63TU2 engine, oil intake snorkel

TO14-1356

# N63TU2 Engine

## 3. Oil Supply

Index	Explanation
A	Oil intake pickup, installation for rear-wheel drive
B	Oil intake pickup, installation for four-wheel drive
1	Intake pickup
2	Oil pump
3	Connector tubes to the characteristic map control valve (oil pressure control)
4	Oil pump drive
5	Pressure oil line

### 3.2.2. Oil pump

The oil pump plays a central role in modern combustion engines. Due to the high power and enormous torque which is present even at low engine speeds, it is necessary to ensure a reliable oil supply. This is necessary on account of the high component temperatures and heavily loaded bearings.

To minimize fuel consumption, the delivery rate of the oil pump must be adapted to the demand.

Compared against the simple volume passages control provided by the pendulum slide cell pump in the N63TU engine, on the N63TU2 engine this volume passages control has been supplemented with a characteristic map.

In order to meet acoustic requirements, the oil pump is designed as an asymmetrical 6-chamber pendulum slide cell pump. This has been made possible as the chamber sizes are different. The chamber sizes vary from chamber to chamber and have different angles. As such, 3 chambers each with 53° and 3 chambers with 67° are used. The difference in chamber size causes irregular pulsations from the oil pressure (which are otherwise regular). This measure has improved the acoustic characteristics of the oil pump.

# N63TU2 Engine

## 3. Oil Supply

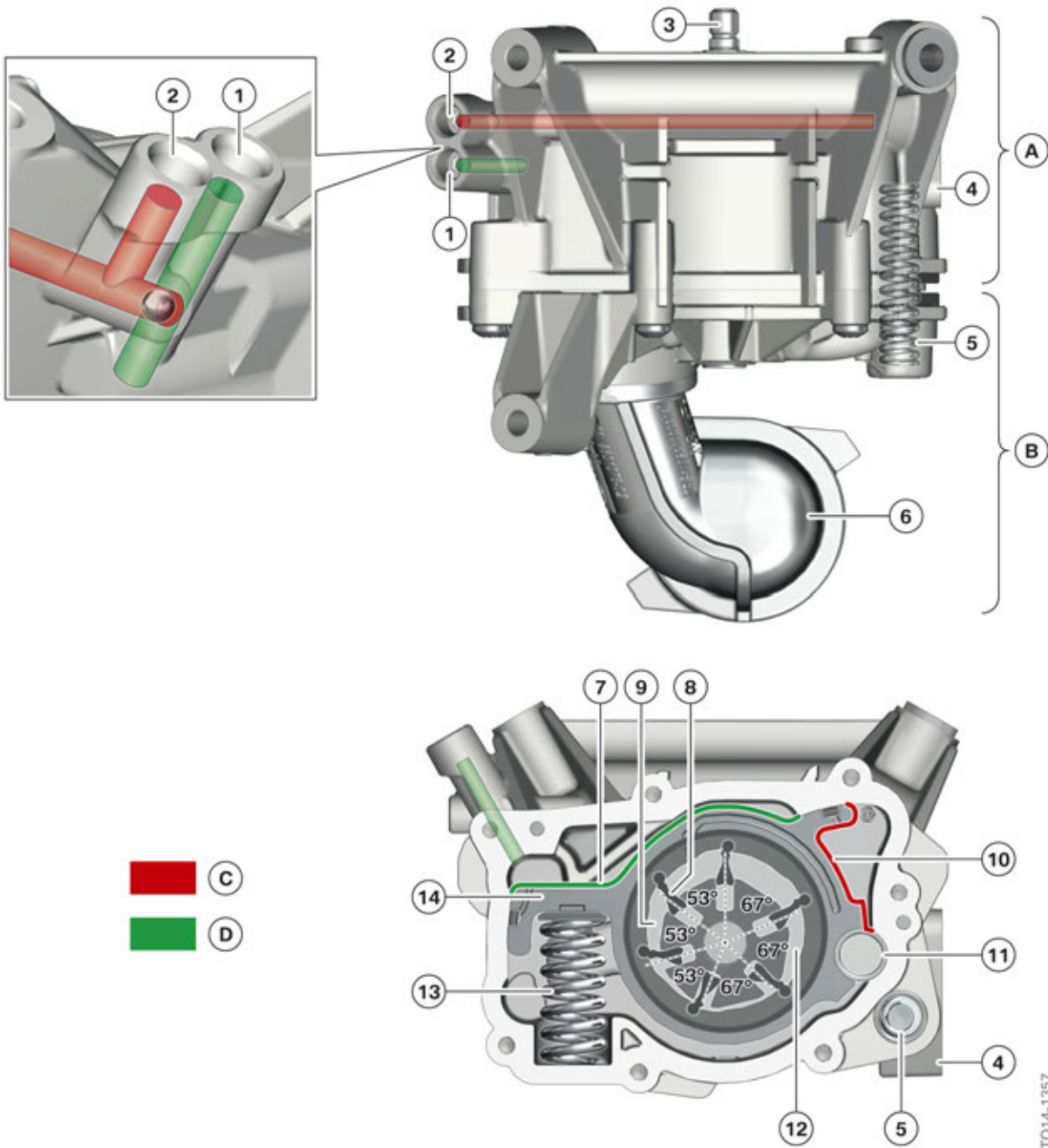

N63TU2 engine, oil pump design

Index	Explanation
A	Oil pump
B	Oil pump cover
C	Second-level control area (emergency operation)
D	Map-controlled control area (normal operation)
1	Oil duct to map-controlled control chamber

# N63TU2 Engine

## 3. Oil Supply

Index	Explanation
2	Oil duct to second-level control chamber
3	Pump shaft
4	Oil pressure channel, pump output
5	Pressure-limiting valve
6	Intake pipe with filter
7	Map-controlled sensing area
8	Rotor with pendulum
9	Suction side
10	Second level control surface
11	Bearing tube (center of rotation)
12	Major thrust face
13	Adjusting ring spring
14	Adjusting ring

A rotor with pendulum rotates as shown in the graphic on the pump shaft. A crescent-shaped cavity arises through the eccentric position. During this process, the oil is drawn into the expanding chamber (intake side) and is delivered via the contracting chamber (pressure side).

When the engine is in operation, oil pressure is admitted to the map-controlled surface and the second-level control surface of the oil pump. Depending on the oil pressure, the adjusting ring is pushed via the center of rotation at the bearing tube to varying degrees of force against the adjusting ring springs. The change in eccentric position of the adjusting ring changes the size of the chamber, and therefore also the intake and pressure power of the oil pump.

To prevent overloading of the oil pump, a filter is installed upstream of the pump inlet. The maximum oil pressure of the oil circuit at the pump outlet is restricted by a pressure limiting valve. The opening pressure of the pressure limiting valve is 23 +/- 1 bar.

### 3.2.3. Map control valve

On the N63TU2 engine, the characteristic map control valve is installed on the oil sump and is connected with the oil pump via bore holes in the oil sump and crankcase using "connector tubes". This design eliminates the need for interference-prone cable ducts into the oil sump.

The map-controlled valve is a proportional valve which can control the oil pressure linearly.

# N63TU2 Engine

## 3. Oil Supply

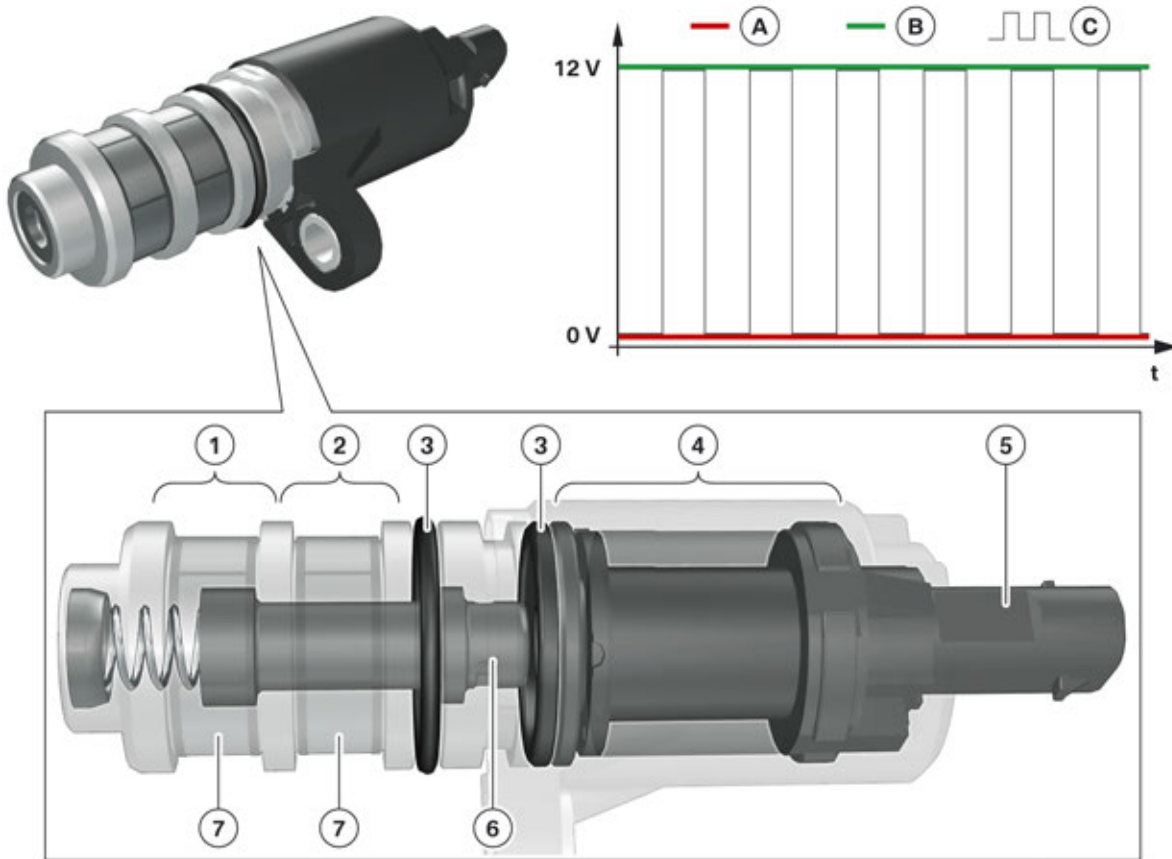

TO14-0590

N63TU2 engine, characteristic map control valve

Index	Explanation
A	Voltage value, maximum actuation for control chamber, maximum pressure
B	Voltage value, minimum actuation for control chamber, depressurized
C	Voltage value at 50% actuation
1	Oil duct to oil pump
2	Oil duct from the oil filter
3	Sealing ring
4	Solenoid coil
5	Electrical connection
6	Valve spool
7	Filter

The oil pressure sensor is connected to the main oil duct and delivers the actual oil pressure at the Digital Motor Electronics (DME). The DME calculates the required target oil pressure based on the engine's operating point and the temperature. A pulse-width modulated signal is sent to the map-controlled valve based on the determined set point deviation. Depending on the pulse-width modulated signal, the width of the valve spool opening in the map-controlled valve varies. Depending



# N63TU2 Engine

## 3. Oil Supply

on the available opening cross-section, more or less engine oil can pass from the oil duct of the oil filter into the oil duct and to the oil pump. This oil passages changes the position of the adjusting ring in the oil pump, and therefore the delivery rate of the pump.

### 3.2.4. Normal operation

The oil pump has 2 separate control loops in order to guarantee normal operation (characteristic map control operation) and emergency operation (second level control operation).

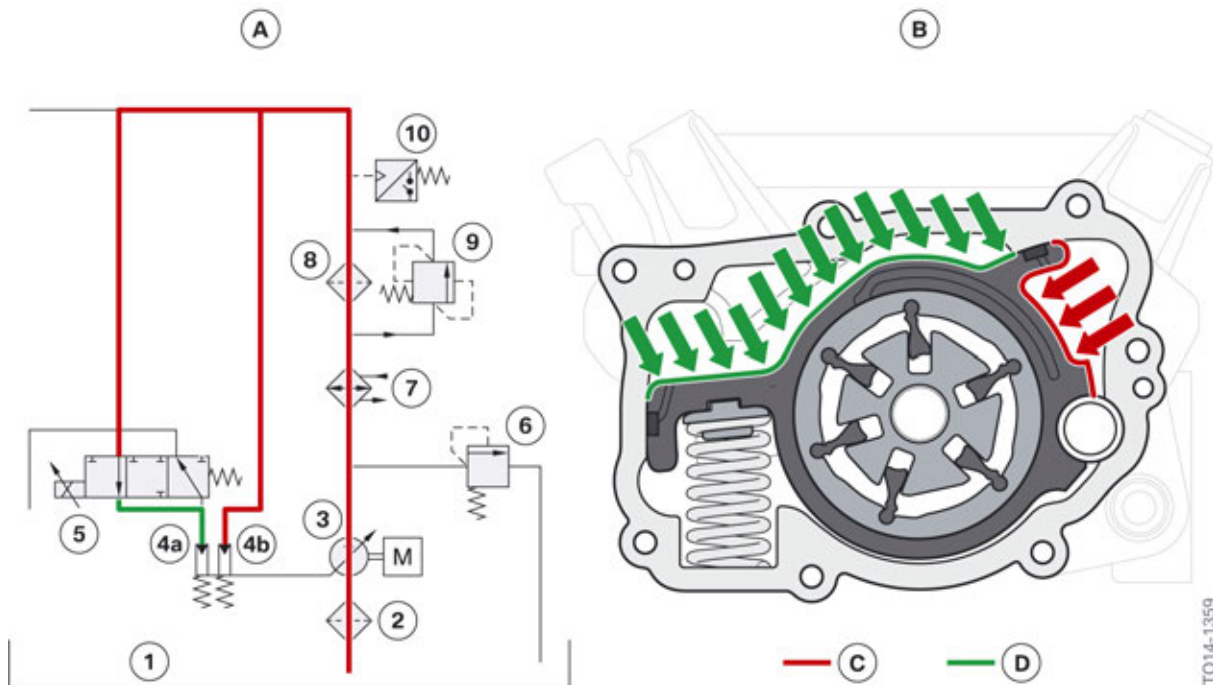

N63TU2 engine, oil circuit in normal operation

Index	Explanation
A	Hydraulic circuit diagram for normal operation
B	Oil pump in characteristic map control operation (normal operation)
C	Volume-passages-controlled oil pressure, oil pump
D	Characteristic map-controlled oil pressure
1	Oil sump
2	Strainer
3	Characteristic map-controlled pendulum slide cell pump
4a	Map-controlled control chamber (normal operation)
4b	Second-level control chamber (emergency operation)
5	Map control valve
6	Pressure-limiting valve

# N63TU2 Engine

## 3. Oil Supply

Index	Explanation
7	Engine oil-to-coolant heat exchanger
8	Oil filter
9	Filter bypass valve
10	Oil pressure sensor

This control loop operates with an external map-controlled valve. The characteristic map control valve controls the oil pressure in the characteristic map control chamber using software in the DME. If the oil pressure in the characteristic map control chamber increases, the surface difference in the control chambers presses the adjusting ring further against the adjusting ring spring, and the pump eccentricity is reduced. This results in a lower volumetric passages.

### 3.2.5. Emergency operation

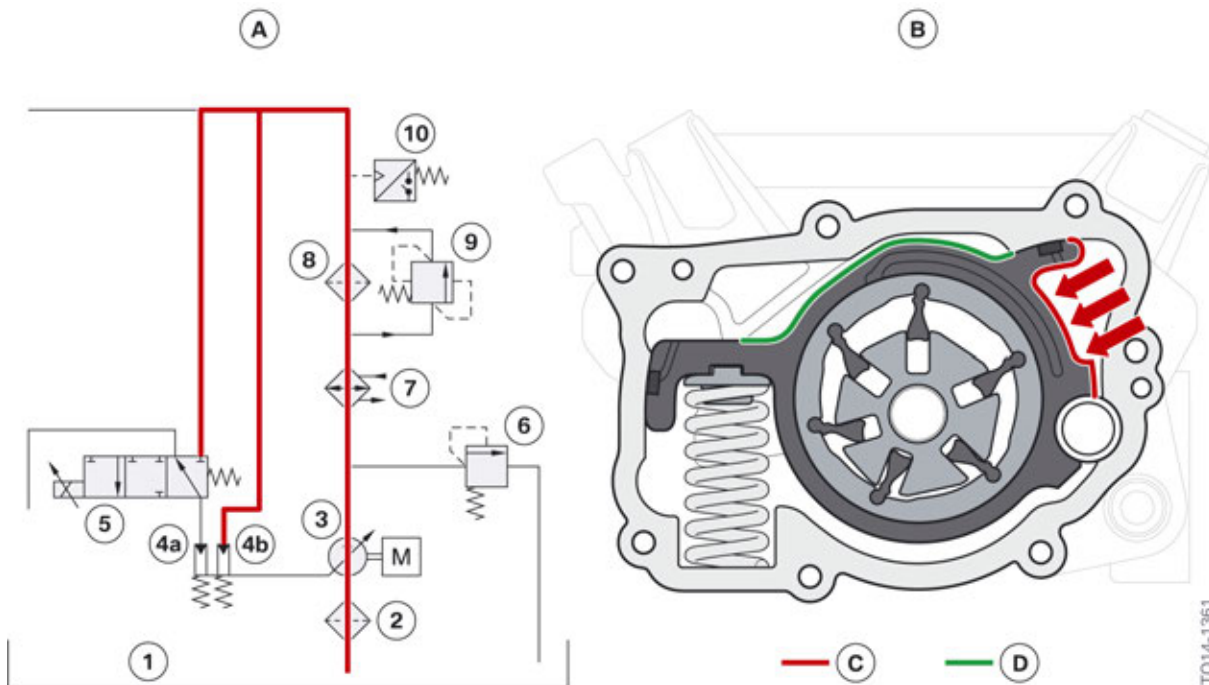

N63TU2 engine, oil circuit in emergency operation

Index	Explanation
A	Hydraulic circuit diagram for emergency operation
B	Oil pump in emergency operation (second level operation)
C	Volume-passages-controlled oil pressure, oil pump
D	Characteristic map-controlled oil pressure
1	Oil sump
2	Strainer
3	Characteristic map-controlled pendulum slide cell pump

# N63TU2 Engine

## 3. Oil Supply

Index	Explanation
4a	Map-controlled control chamber (normal operation)
4b	Second-level control chamber (emergency operation)
5	Map control valve
6	Pressure-limiting valve
7	Engine oil-to-coolant heat exchanger
8	Oil filter
9	Filter bypass valve
10	Oil pressure sensor

During emergency operation, the system operates without the map control by the Digital Motor Electronics (DME). In this operating condition the characteristic map control valve is de-energized and releases the oil duct from the characteristic map control chamber to the oil sump. The purpose of emergency operation is to keep the oil pump at a constant, volume-passages-controlled oil pressure level. For this purpose, the oil pressure is guided directly from the main oil duct into the second level control chamber. This then corresponds to the principle of a volume-passages-controlled oil pump without characteristic map control, as on the N63TU predecessor engine.

# N63TU2 Engine

## 3. Oil Supply

### 3.3. Oil cooling and filtering

The N63TU2 engine possesses the full-passages oil filter familiar from the N63TU engine. It is screwed into the oil sump from below. A filter bypass valve is integrated in the oil filter housing.

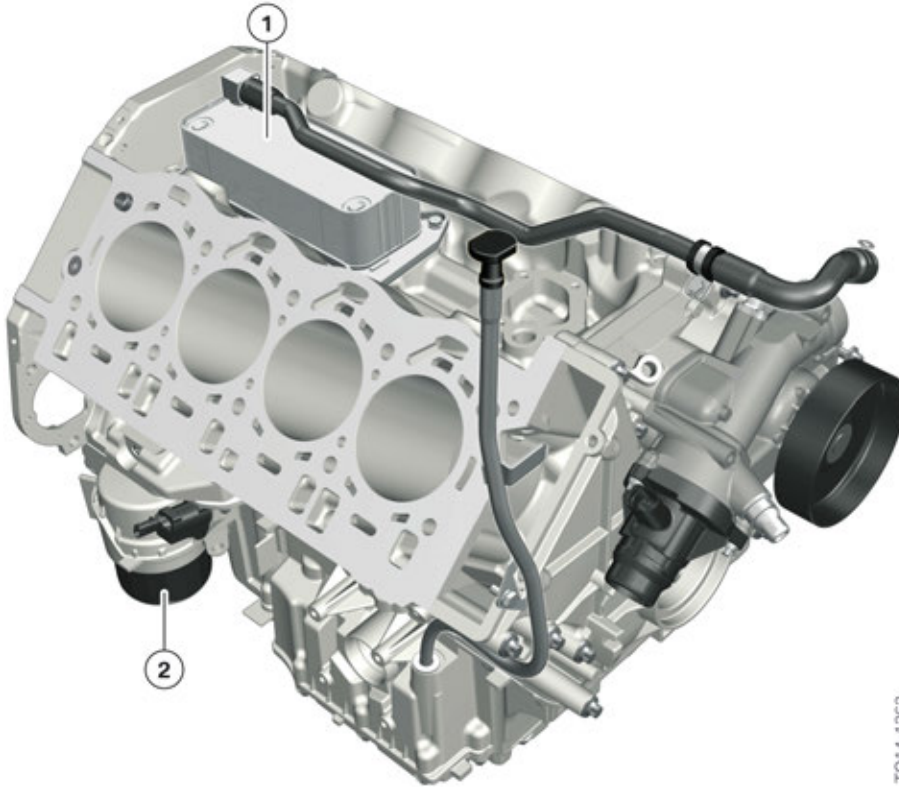

TO14-1363

N63TU2 engine, oil filter module and engine oil/coolant heat exchanger

Index	Explanation
1	Engine oil-to-coolant heat exchanger
2	Oil filter module

# N63TU2 Engine

## 3. Oil Supply

### 3.3.1. Oil cooling

In order to cool the engine oil, the N63TU2 engine has an engine oil/coolant heat exchanger that is connected directly to the crankcase and is a completely new component. As such it replaces the familiar external air/engine oil heat exchanger from the N63TU engine (which was installed on the right next to the cooling module). By integrating the engine oil/coolant heat exchanger into the V space of the N63TU2 engine, the thermostatic control and the associated components could be removed, as could the oil lines and the engine oil/air heat exchanger in the front of the vehicle.

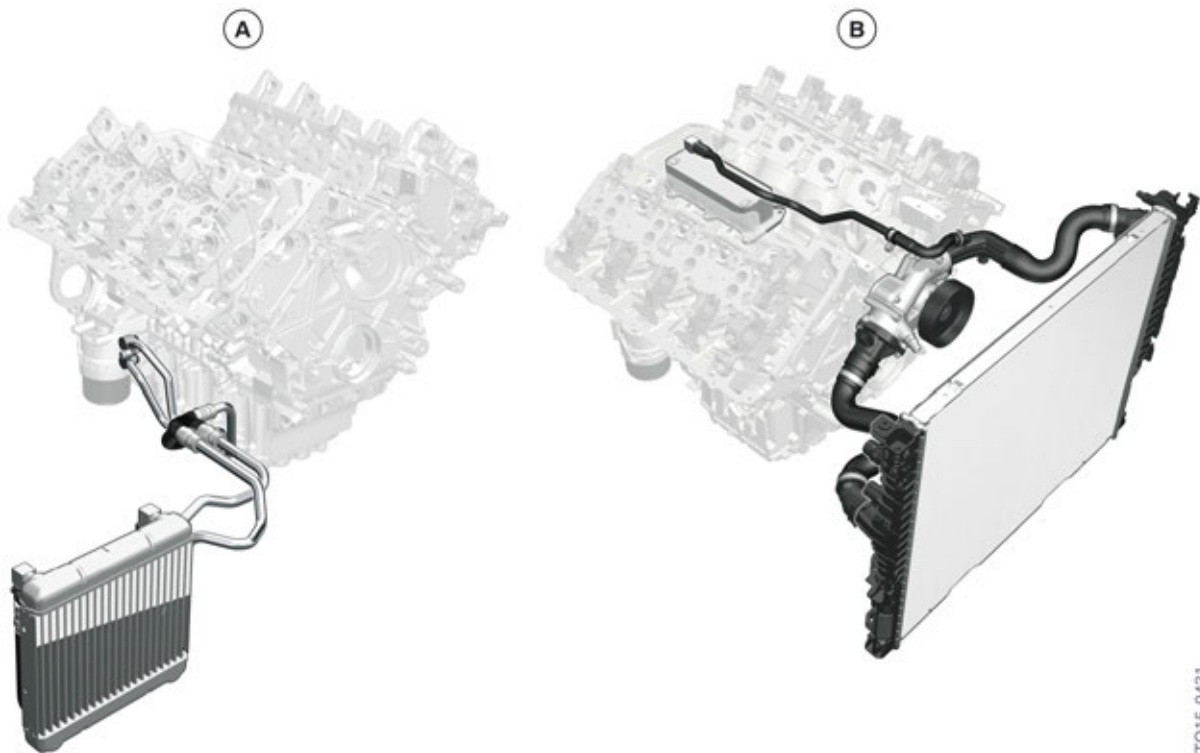

N62TU2 engine, installation of engine oil cooling components

Index	Explanation
A	N63TU engine
B	N63TU2 engine

The engine oil/coolant heat exchanger meets all engine oil cooling requirements up to the lowest engine speeds. It also influences the engine oil temperature when the engine is warming up, without risks or additional interventions in the cooling power.

# N63TU2 Engine

## 3. Oil Supply

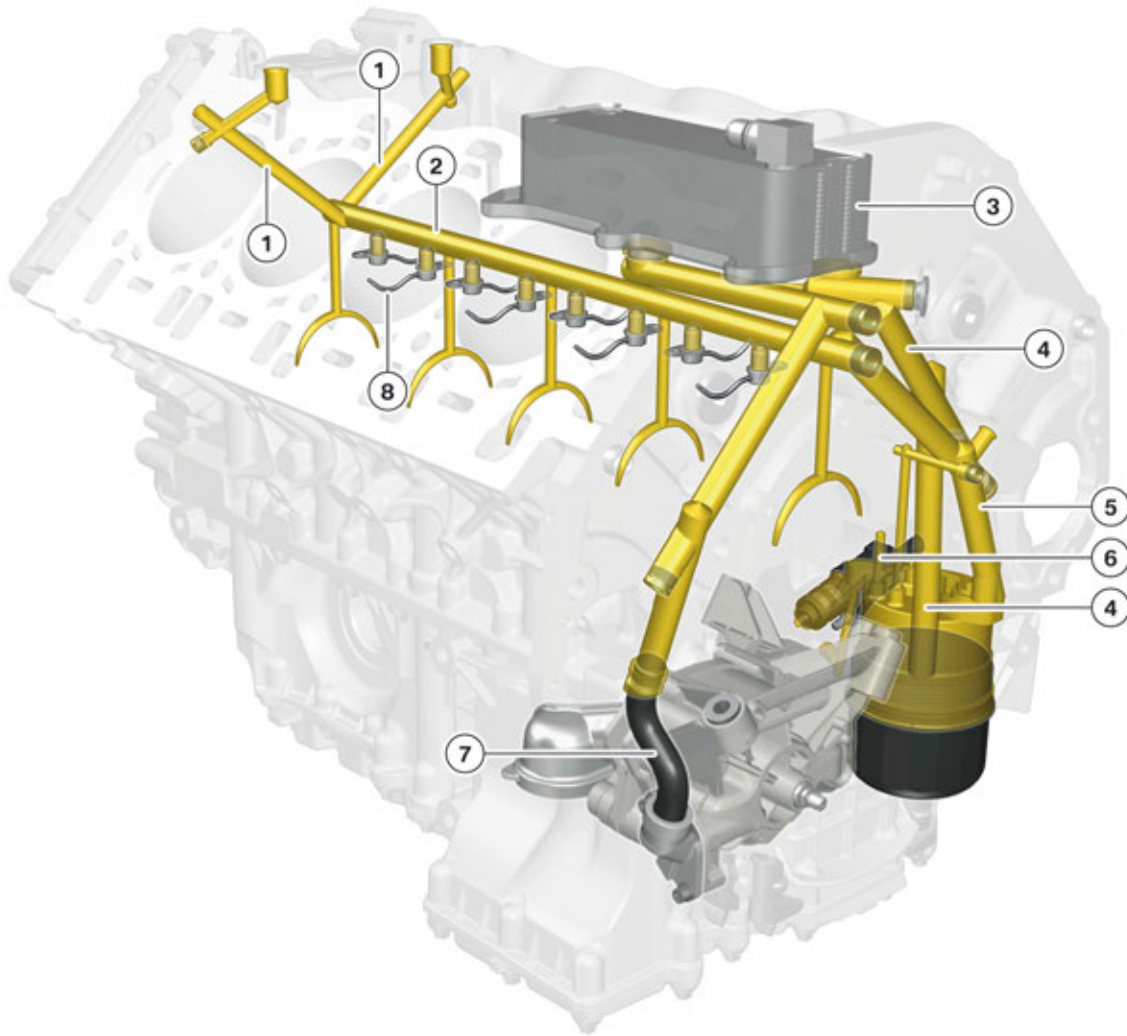

TO14-1364

N62TU2 engine, oil passages

Index	Explanation
1	Feed line-supply-cylinder heads
2	Main oil duct
3	Engine oil-to-coolant heat exchanger
4	Cooled raw oil to the oil filter
5	Filtered oil from the oil filter
6	Map control valve
7	Raw oil from the oil pump
8	Oil spray nozzles

# N63TU2 Engine

## 3. Oil Supply

The cooling of the engine oil is ensured by the engine radiator. As it is integrated into the engine coolant circuit, the most important functional criterion has been met. The cooling power can now be varied for the engine oil using the electrical radiator fan, regardless of the air stream and ambient temperature. This allows higher cooling power to be selected, which may be required in the case of low speeds or when the vehicle is at a standstill, for example.

Further advantages of the engine oil/coolant heat exchanger connected to the crankcase are:

- Closed oil circuit. Protection against contamination as external lines are screwed in the plant and during a service.
- No sound transfer from the oil pump to the oil lines screwed to the vehicle.



---

If the engine oil/coolant heat exchanger is removed and refitted, care must be taken to ensure that no contamination enters. Coolant must not enter the bore holes for the engine oil, and engine oil must not enter the coolant bore holes. Coolant bore holes and engine-oil bore holes on the crankcase and on the engine oil/coolant heat exchanger must be sealed immediately using suitable plugs.

---

### 3.3.2. Oil filtering

Naturally the N63TU2 engine has a filter bypass valve which can open a bypass round the filter if, for example, the engine oil is cold and viscous. This occurs if the pressure difference between before and after the filter exceeds approx. 2.5 bar. This ensures that the filter is bypassed much less frequently and any dirt particles are reliably filtered out. The filter bypass valve is integrated in the oil filter housing.

## 3.4. Oil monitoring

### 3.4.1. Oil level

In order to monitor the oil level, the N63TU2 uses the latest generation of oil-level sensors. The oil-level sensor is a PULS 3 oil-level sensor. The PULS 3 oil-level sensor is characterized by new control electronics with faster and more robust starting characteristics. The abbreviation "PULS" stands for "Packaged Ultrasonic Level Sensor" and, as the name implies, ultrasonic measuring technology is used as the basis. The oil-level sensor is screwed into the oil sump from below and, in addition to the oil level, also measures the oil temperature using an ultrasonic method. The measuring range of the oil-level sensor is 18 mm to 95.8 mm. If engine oil is temporarily over-filled, an air bubble in the cap area stops any engine oil from entering the oil-level sensor. An oil level dipstick is also installed on the N63TU2 engine.

### 3.4.2. Oil pressure sensor

In contrast to the N63TU (in which an oil pressure switch was installed), the N63TU2 uses an oil pressure sensor to monitor the oil pressure.

# N63TU2 Engine

## 3. Oil Supply

### 3.4.3. Oil temperature sensor

In addition to the oil temperature sensor in the oil-level sensor, an oil temperature sensor is installed behind the starter motor in the pressure oil duct after the engine oil/coolant heat exchanger. This engine oil temperature sensor is a new part for the N63TU2 engine. In contrast, on the N63TU engine the engine oil temperature was modelled using various parameters. The engine oil temperature sensor monitors the oil temperature once it exits the engine oil/coolant heat exchanger. The measured value is used to control the dynamic heat transfer to cool or heat the engine oil via the coolant.

### 3.5. Oil spray nozzles

In the N63TU2 engine, components which cannot be reached directly by an oil duct are lubricated and/or cooled by oil spray nozzles.

#### 3.5.1. Piston crown cooling

The oil spray nozzles for piston crown cooling, as used in the N63TU2 engine, are in principle familiar. They incorporate a non-return valve to enable them to open and close only from a specific oil pressure. The opening pressure and closing pressure have been adjusted compared with the N63TU engine. Each cylinder has its own oil spray nozzle, which obtains the correct installation position through its design. In addition to the piston crown cooling, these are also responsible for the lubrication of the wrist pins.

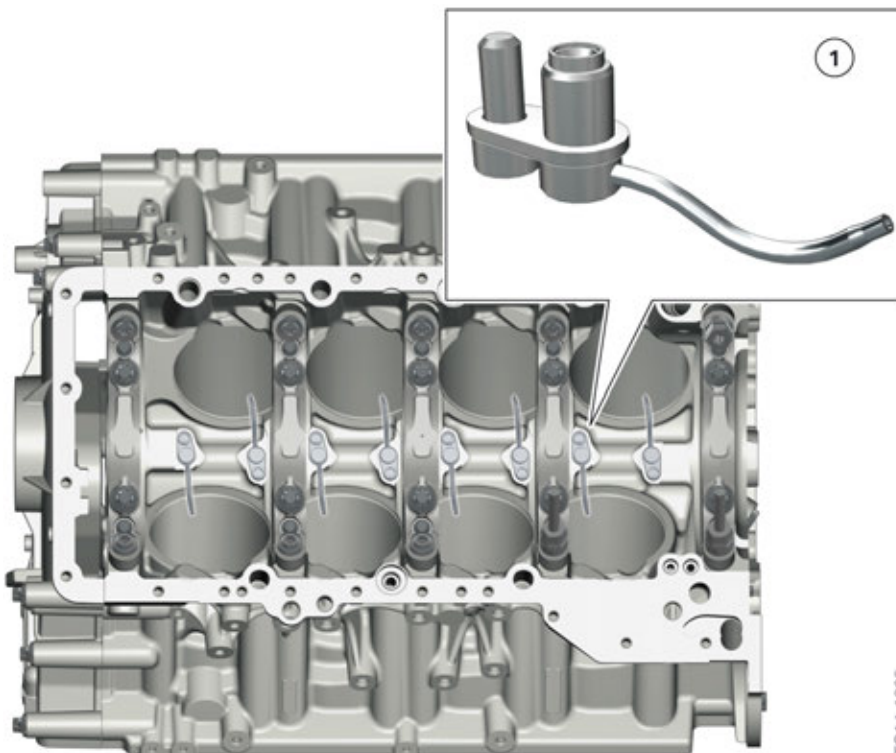

TO14-1365

N63TU2 engine, oil spray nozzles for the piston crown cooling



# N63TU2 Engine

## 3. Oil Supply

Index	Explanation
1	Oil spray nozzle

### Function

	N63TU engine	N63TU2 engine
Opening pressure	2.25 - 2.65 bar	3.3 – 3.7 bar
Closing pressure	2.0 bar	3.0 bar

On the N63TU2 engine, the characteristic map control of the volume-passages-controlled oil pump is a key factor in ensuring compliance with ULEV II. Thanks to the volume-passages-controlled oil pump, supplemented by the characteristic map control, the oil pressure can be reduced to under 3.3 bar in the warm-up phase. As a result of this reduction, there is insufficient oil pressure at the oil spray nozzles to open the nozzles. This measure also suppresses the intended function of the oil spray nozzles, namely to cool the piston crowns in the warm-up phase. The effect of this is that the piston crowns heat up faster and thus less fuel is condensed at the cold piston crowns in the warm-up phase, resulting in higher particle values as a result of unburned fuel. When a certain operating temperature is reached, the oil pressure is increased by the characteristic map control of the volume-passages-controlled oil pump, which raises the oil pressure to above the opening pressure for the oil spray nozzles and thus activates the piston crown cooling.

### 3.5.2. Chain drive

The chain drive in the N63TU2 engine is divided into an upper section, the camshaft drive, and a lower section, the oil pump drive.

#### Camshaft drive

The oil spray nozzles for the lubrication of the timing chains are integrated in the respective chain tensioner of the banks. They spray the oil directly onto the timing chain. A throttle in the oil spray nozzle limits the emerging oil. The timing chain of the camshaft drive is designed as a toothed sleeve-type chain.

# N63TU2 Engine

## 3. Oil Supply

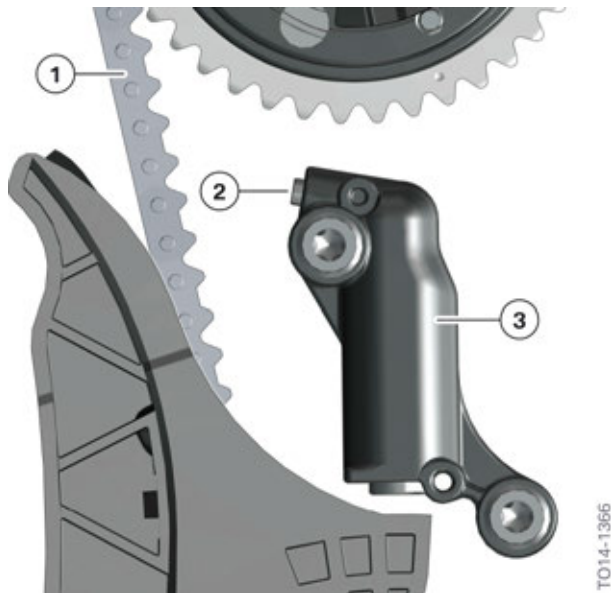

N63TU engine, chain tensioner with oil spray nozzle for timing chain

Index	Explanation
1	Toothed sleeve-type chain
2	Oil spray nozzle
3	Chain tensioner

### Oil pump drive

The oil pump is driven via a sleeve-type chain by the crankshaft. The sleeve-type chain is kept tensioned by a tensioning rail. The secondary drive is lubricated via the oil sump.

### 3.5.3. Camshaft

The oil supply of the chain tensioner, the hydraulic valve clearance compensating elements and the bearing positions in the cylinder head is effected via a rising pipe from the engine housing in the cylinder head. A non-return valve in the cylinder head in the rising pipe prevents the oil duct idling.

### 3.5.4. Valvetronic servomotor

The worm gear for adjusting the eccentric shaft is lubricated using the oil spray from the camshaft.

# N63TU2 Engine

## 4. Cooling

The cooling system also has similarities with the N63TU engine. The engine and charge air cooling both have separate cooling circuits. The cooling of both control units of the Digital Motor Electronics (DME) has been integrated into the coolant circuit of the charge air cooling. The coolant circuit for the engine and exhaust turbochargers is also called the high-temperature coolant circuit. The coolant circuit for the charge air cooling and DME control units is known as the low-temperature coolant circuit.

A brand-new feature is the thermal management system inside the engine, known as SCC "**Split Cooling Combined**", which includes the engine cooling (high-temperature circuit).

Under the designation "SCC", the cooling concept inside the engine is described below. The main aim of this is to allow the engine to warm up faster. Thanks to the faster warm-up (supported by the SCC concept), significant reductions in consumption and emissions were again achieved in the N63TU2 by reducing friction during warm-up.

# N63TU2 Engine

## 4. Cooling

### 4.1. System overview

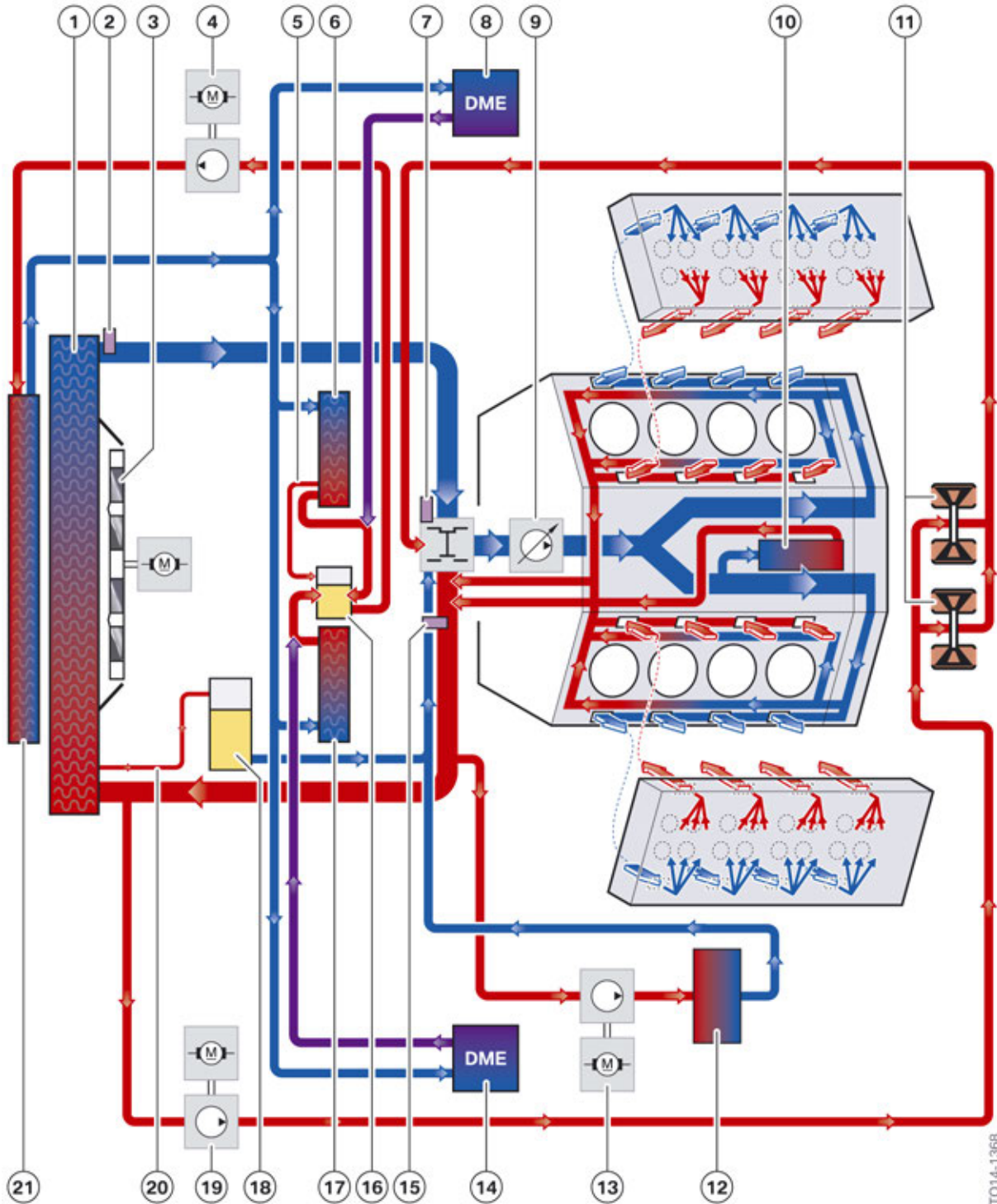

TO14-1368

N63TU2 engine, cooling circuit, ECE version

# N63TU2 Engine

## 4. Cooling

Index	Explanation
1	Radiator
2	Coolant temperature sensor at radiator outlet
3	Electric fan
4	Electric coolant pump for the cooling circuit of the charge air and DME
5	Ventilation line for charge air cooling
6	Charge air cooler, bank 1
7	Characteristic map thermostat with heating element and travel sensor
8	Digital Motor Electronics (DME) 1
9	Temperature-dependent coolant pump
10	Engine oil-to-coolant heat exchanger
11	Exhaust turbocharger
12	Heat exchanger
13	Electric auxiliary coolant pump for vehicle heating
14	Digital Motor Electronics (DME) 2
15	Coolant temperature sensor at engine outlet
16	Coolant expansion tank, charge air and DME
17	Charge air cooler, bank 2
18	Coolant expansion tank, engine
19	Electric auxiliary water pump for exhaust turbocharger cooling
20	Ventilation line for cooling circuit, engine
21	Cross-passages cooler for the cooling circuit of charge air and DME

### 4.1.1. Cooling circuit, engine

The engine cooling system is an independent coolant circuit known as the **"high-temperature circuit"**. It comprises the conventional engine cooling and cooling of the turbochargers. Even the vehicle interior heating is supplied by the coolant circuit of the engine cooling system.

The engine cooling is ensured using a conventional mechanical coolant pump. Overall different versions of the cooling system can be installed depending on the equipment and national-market version of the vehicle. There is also the variant for hot countries. In this case, an external radiator is connected on the left and right in the direction of travel, parallel to the coolant circuit. The additional radiator is equipped with a non-return valve with compression spring to prevent a return by the electric auxiliary water pump in the case of a low volumetric passages of the coolant.

The electric fan has a nominal power of 850 W.

The following graphics show the installation locations and layout of the components.

# N63TU2 Engine

## 4. Cooling

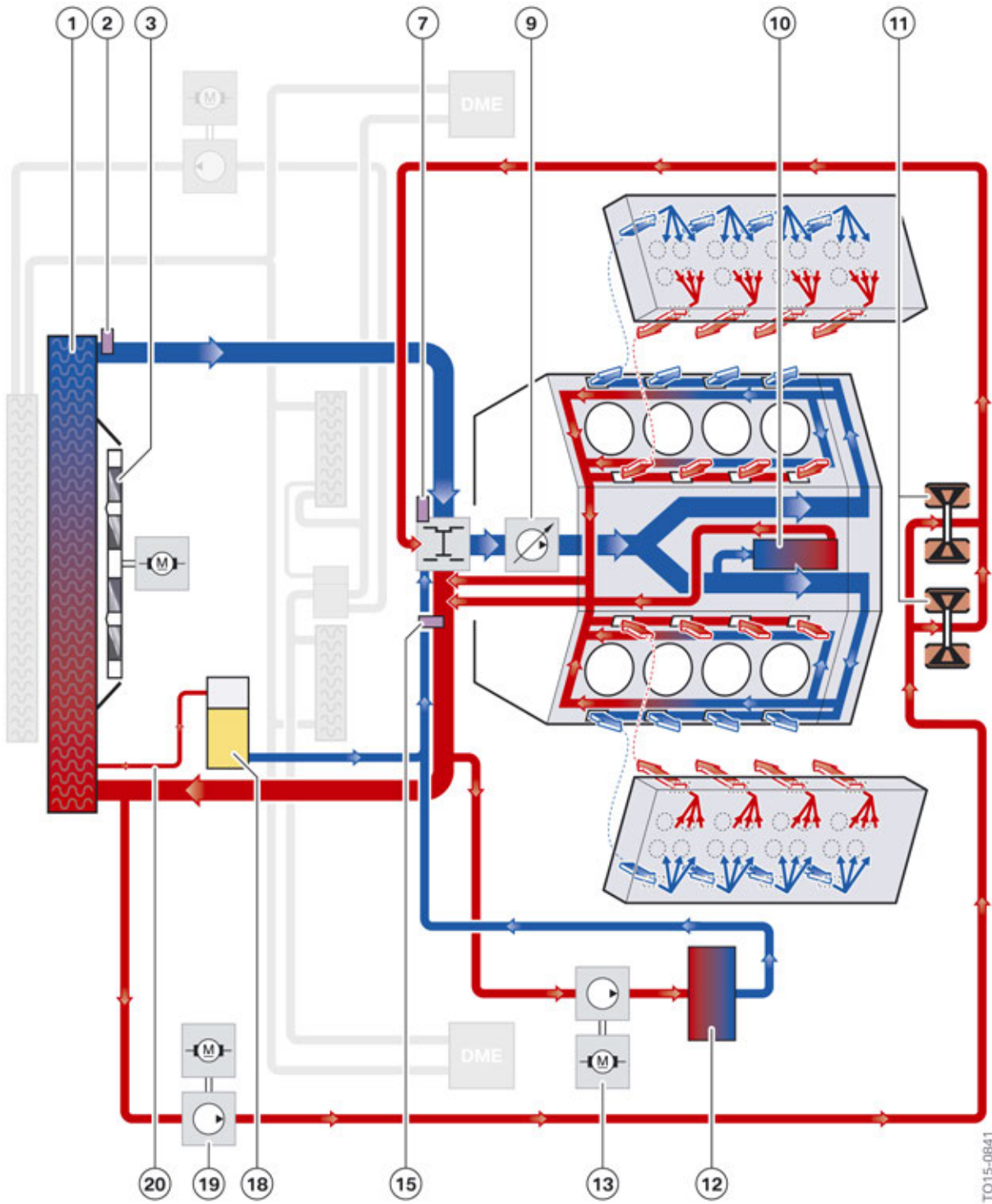

TO15-0841

N63TU2 engine, cooling circuit, engine, ECE version

# N63TU2 Engine

## 4. Cooling

Index	Explanation
1	Radiator
2	Coolant temperature sensor at radiator outlet
3	Electric fan
7	Characteristic map thermostat with heating element and travel sensor
9	Temperature-dependent coolant pump
10	Engine oil-to-coolant heat exchanger
11	Exhaust turbocharger
12	Heat exchanger
13	Electric auxiliary coolant pump for vehicle heating
15	Coolant temperature sensor at engine outlet
18	Coolant expansion tank, engine
19	Electric auxiliary water pump for exhaust turbocharger cooling
20	Ventilation line for cooling circuit, engine

### Split Cooling (SC)

In order to ensure optimal heat distribution between the cylinder head and crankcase during the warm-up phase, it would be ideal to be able to supply these two components individually with the required coolant. The ideal solution could be if it were possible during warm-up to completely block the coolant supply for the crankcase and to supply the entire volume of coolant to the cylinder head. Both components would therefore always be in an ideal temperature range for low fuel consumption, ideal emission behavior and, in particular, for the engine's carbon dioxide emissions. One possible solution in this context would be to disconnect the coolant circuit of the crankcase from the coolant circuit of the cylinder head using a shutoff valve. However, if the engine's temperature characteristics mean that the crankcase has to be cooled, then the coolant circuit of the crankcase could be included by opening the shutoff valve. This would then be what is known as a pure **Split Cooling** concept.

### Split Cooling Combined (SCC)

It was not possible to use the Split Cooling concept for the N63TU2 engine, as there is insufficient space for the additional installation of shutoff valves for the two coolant circuits for the crankcase and cylinder head. The N63TU2 engine therefore uses a modified version of the Split Cooling concept known as the Split Cooling Combined (SCC) concept. Instead of shutoff valves (which would allow the coolant circuits for the crankcase and cylinder head to be separated), on the SCC concept the coolant circuits for the cylinder head and crankcase are combined in a **parallel** configuration. Here, during the cooling-down period and when the thermostat is open, **80%** of the coolant flows through the cylinder head with the cylinder bridge cooling integrated into the crankcase, and **20%** of the coolant flows through the crankcase. During the warm-up phase (during which the characteristic map-dependent coolant pump is only operated at 10% volumetric passages), **8%** of the coolant is supplied to the cylinder head and **2%** of the coolant is supplied to the crankcase.

As such, the SCC concept allows the warm-up phase for the N63TU2 to be significantly shortened, thereby optimizing fuel consumption and emission behavior and, in particular, the CO<sup>2</sup> emissions of the N63TU2 engine.

# N63TU2 Engine

## 4. Cooling

On an engine block that is not equipped with the SCC concept, 100% of the coolant flows through the crankcase and cylinder head by means of **longitudinal distribution**.

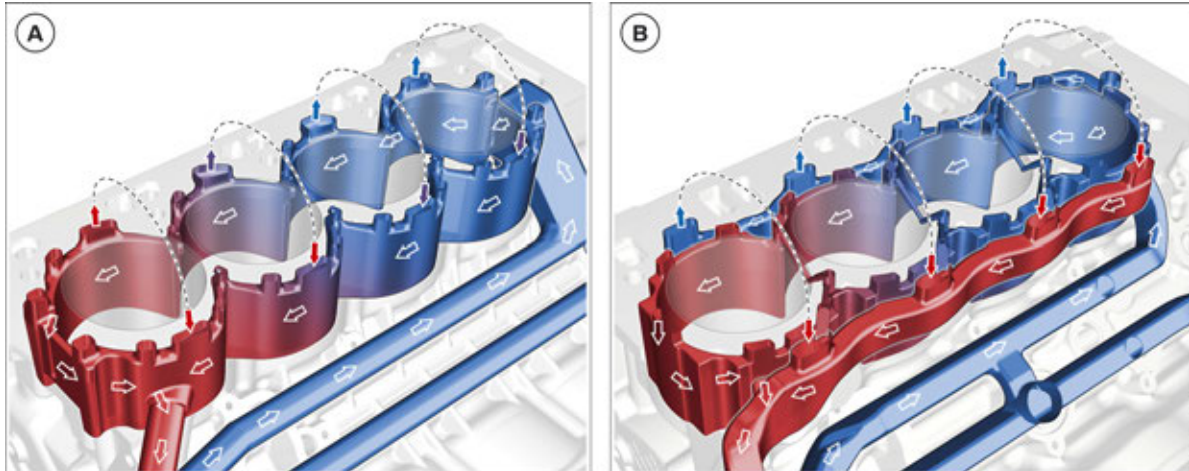

N63TU2 engine, coolant flows

Index	Explanation
A	Longitudinal distribution on N63TU engine
B	Parallel configuration on N63TU2 engine

On the SCC concept, **20%** of the available coolant flows along the crankcase during the cooling-down period and when the thermostat is open. All cylinders always benefit from the same coolant passages and the cooler coolant is always conveyed to the rear cylinders (which are subjected to high thermal stresses). The coolant for cooling the cylinder head is conveyed along the crankcase via the outer gallery. During the cooling-down period and when the thermostat is open, **80%** of the coolant is used for cooling the cylinder heads via the defined apertures in the cylinder head gasket. The coolant then flows through the cylinder head from the intake side to the outlet side, is collected on the outlet side in a collecting duct together with the coolant for cooling the crankcase, and conveyed to the coolant pump again.

The V-shaped, drilled bridge cooling in the crankcase is supplied from the cylinder head through separate bore holes. The outflow runs through short coolant ducts into the coolant gallery in the cylinder jacket on the outlet side.

In order to ensure that sufficient coolant is available at all cylinders in the cylinder head in line with the temperature characteristics (hot rear cylinder–higher coolant quantity), the passages rates and cooling section lengths are adapted to specific cylinders thanks to the geometric design of the coolant ducts in the crankcase. The geometry of the coolant ducts has been selected such that all paths for the coolant to each individual cylinder have the same length, but the cross-sections of the coolant ducts are adapted in line with the coolant quantity required by each cylinder.

Thanks to this design for the coolant ducts on the N63TU2 engine, the system resistance in the cooling system as compared against the N63TU engine was reduced by 40% to 0.83 bar (N63TU = 1.34 bar).



# N63TU2 Engine

## 4. Cooling

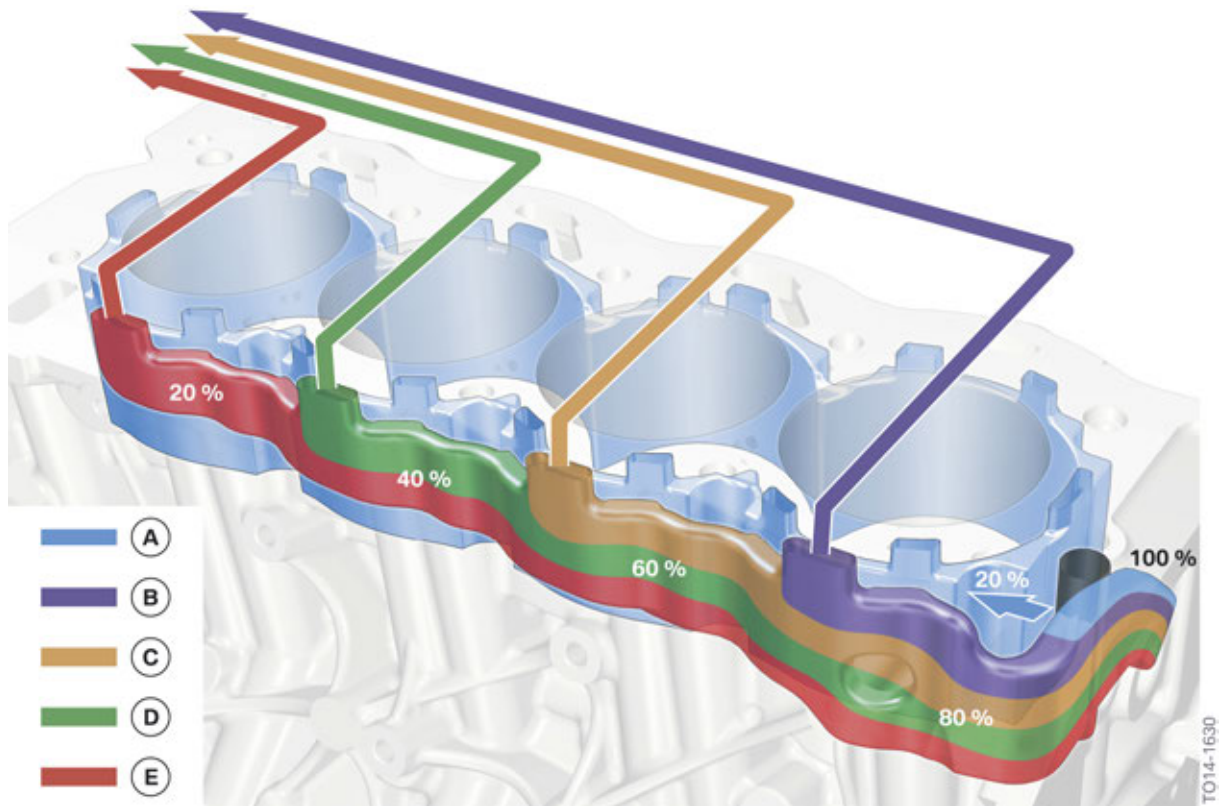

N63TU2, coolant distribution, cylinder bank 2

Index	Explanation
A	Coolant section, crankcase
B	Coolant section, cylinder head-cylinder 8
C	Coolant section, cylinder head-cylinder 7
D	Coolant section, cylinder head-cylinder 6
E	Coolant section, cylinder head-cylinder 5

# N63TU2 Engine

## 4. Cooling

### Components Cooling circuit

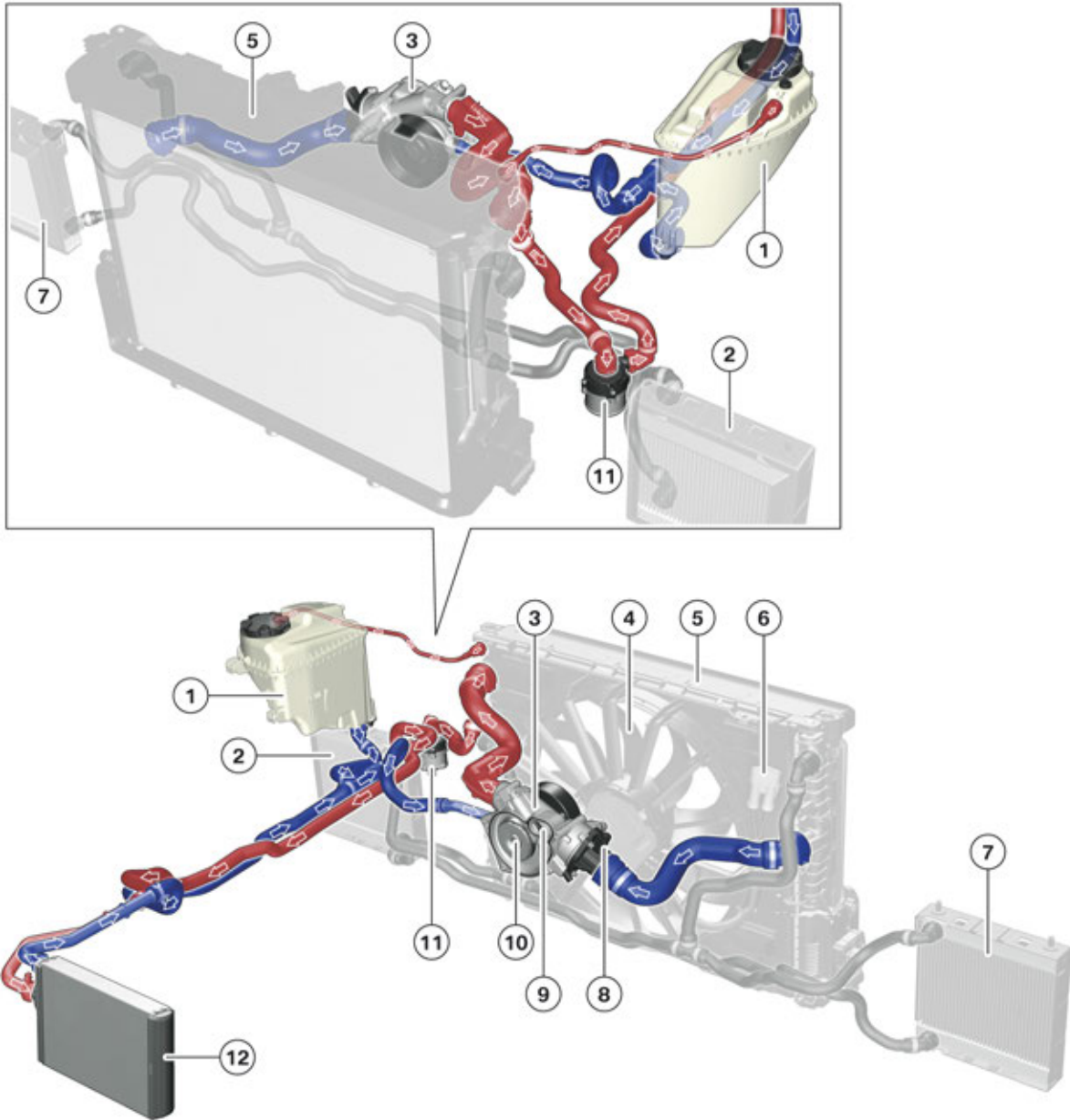

N63TU2 engine, cooling system components

Index	Explanation
1	Expansion tank
2	Auxiliary radiator, engine
3	Coolant pump
4	Electric fan
5	Radiator

# N63TU2 Engine

## 4. Cooling

Index	Explanation
6	Plug connection
7	Auxiliary radiator, engine
8	Characteristic map thermostat with travel sensor
9	Return of heated coolant from engine housing to coolant pump
10	Supply of cooled coolant via impeller to the engine housing
11	Electric auxiliary water pump
12	Heat exchanger

### Characteristic map-dependent coolant pump

The N63TU2 engine uses a characteristic map-dependent coolant pump, the main function of which corresponds to the familiar temperature-dependent coolant pump from the N63TU engine. The new feature on the characteristic map-dependent coolant pump is that a heating element has been integrated into the thermal actuator. The characteristic map-dependent coolant pump is therefore an active element of the **"Split Cooling Combined"** (SCC) concept.

A thermal actuator (5) with an adjusting piston (4) made from plastic is integrated into the coolant pump. The adjusting piston is positioned over an inner second preloaded spring (3) and is supported at the lower end over the thermal actuator. The adjusting piston can thus be moved upwards over the thermal actuator, but axial movement is also allowed. The thermal actuator is secured over a long preloaded spring (2) with the cover (1) in the coolant housing.

The thermal actuator (5) can also be influenced by the Digital Motor Electronics (DME) via the heating element (6) depending on the characteristic map.

The adjusting piston (4) reaches over a lug into the groove of the ring valve (6), which can move outwards on the fixed ring insert (7) via guiding grooves. It is thus possible to fade the impeller (8) by the ring valve (6).

# N63TU2 Engine

## 4. Cooling

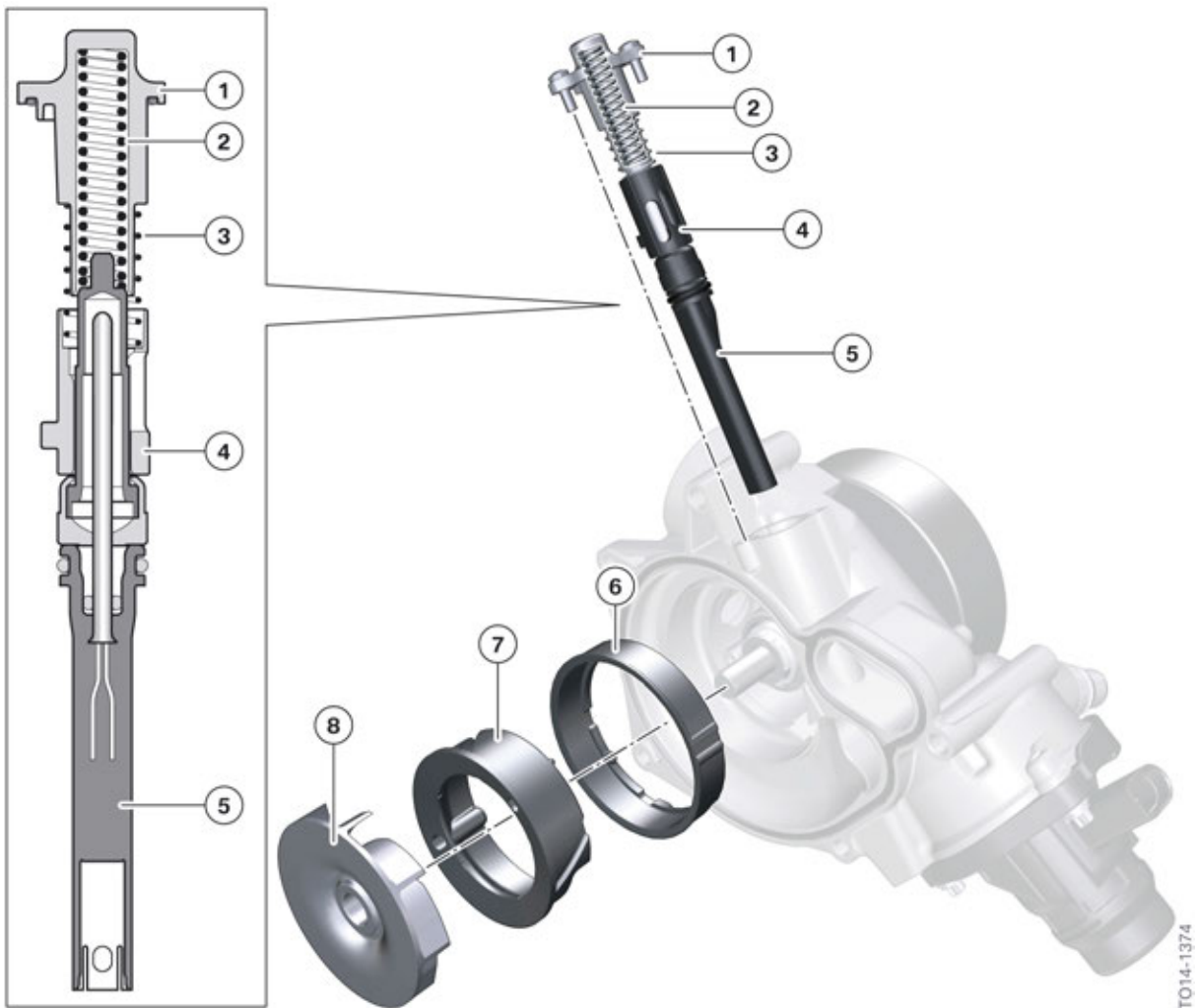

N63TU2 engine, coolant pump components

Index	Explanation
1	Cover
2	Spring for thermal actuator
3	Spring for adjusting piston
4	Adjusting piston made out of plastic
5	Thermal actuator with electrical heating element
6	Ring valve
7	Ring insert
8	Impeller

The graphic below shows the different positions of the ring valve. Upon a cold start of the engine the ring valve is positioned over the impeller so that only a small volumetric passages of 10% arises. The operating temperature of the engine is reached faster, which lowers fuel consumption and reduces

# N63TU2 Engine

## 4. Cooling

carbon dioxide emissions. If the coolant operating temperature of 98°C / 208°F is exceeded, the thermal actuator switches and moves the adjusting piston. At the same time the ring valve is moved open. The impeller is now fully exposed, with 100% of the volumetric passages is available.

This process can now also be influenced by the DME (which activates the electrical heating element) depending on the characteristic map.

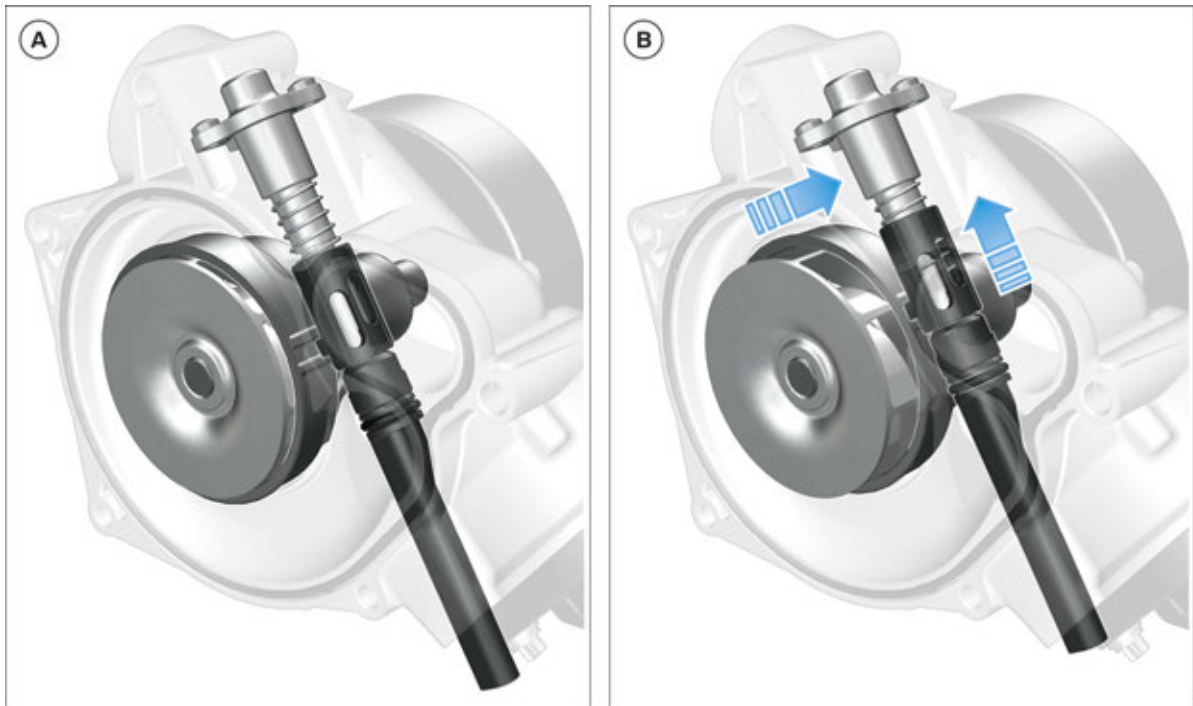

N63TU2 engine, function of the temperature-dependent coolant pump

Index	Explanation
1	10% volumetric passages of the coolant, ring valve covers the impeller
2	100% volumetric passages, ring valve moves away from the impeller

### Basic operating principle:

The opening point of the thermal actuator on the N63TU2 engine was increased by 18°C compared with the N63TU engine. Whereas on the N63TU engine the thermal actuator released a delivery rate of 100% at 80°C / < 176°F, on the N63TU2 engine this was increased to 98°C / < 208°F. As such, the engine temperature in warm-up phase I was increased to 98°C / < 208°F. During warm-up phase II until the thermostat opens, the engine temperature can reach 105°C / < 221°F.

By increasing the opening point of the thermal actuator to 98°C / < 208°F and thus providing a coolant pump delivery rate of 100%, the heat retention in the N63TU2 engine block was safeguarded. As such, the following aims were achieved with the N63TU2 engine:

- Further reduction in consumption.
- Further reduction in carbon dioxide emissions.
- Faster, longer and more efficient provision of heating.

# N63TU2 Engine

## 4. Cooling

- Warm-up phase I: 10% delivery rate at an engine coolant temperature of  $-40^{\circ}\text{C}$  to  $+98^{\circ}\text{C}$ . Coolant delivered to the engine block, engine oil/coolant heat exchanger, exhaust turbocharger and vehicle interior as required.
- Warm-up phase II: 100% delivery rate at an engine coolant temperature of  $+98^{\circ}\text{C}$  to  $+105^{\circ}\text{C}$ . Coolant delivered to the engine block, engine oil/coolant heat exchanger, exhaust turbocharger and vehicle interior as required.
- Cooling-down period: 100% delivery rate at an engine coolant temperature as from  $+105^{\circ}\text{C}$ . Coolant delivered to the engine block, engine oil/coolant heat exchanger, exhaust turbocharger, engine radiator and vehicle interior as required.

In addition to the temperature-dependent switch point of the thermal actuator there is a speed-dependent safety function. This serves to protect the engine from overheating if a very high engine performance is demanded during a cold-start phase. From an engine speed of 3,500 rpm, the impeller is released completely via another adjusting mechanism so that a delivery rate of 100% is immediately available. This is realized via return of the coolant pressure from the pressure auger directly to the ring valve. The adjusting piston is axially disconnected from the thermal actuator as described above and acts against a second preloaded spring. In the vane chamber a speed-dependent coolant pressure builds up which presses the ring valve against the spring force of the adjusting piston in an open direction. The passages rate increase is effected without delay.

In summary, a delivery rate by the coolant pump arises:

- 10% at an engine coolant temperature  $< 98^{\circ}\text{C}$  /  $< 208^{\circ}\text{F}$  and an engine speed  $< 3500$  rpm
- 100% at an engine coolant temperature  $< 98^{\circ}\text{C}$  /  $< 208^{\circ}\text{F}$  and an engine speed  $> 3500$  rpm
- 100% at an engine coolant temperature  $> 98^{\circ}\text{C}$  /  $< 208^{\circ}\text{F}$

Due to the characteristic map control of the switching coolant pump via the DME, it is also possible to increase the volumetric passages to a delivery rate of 100% if required, even with a coolant temperature of less than  $98^{\circ}\text{C}$  /  $< 208^{\circ}\text{F}$  and an engine speed of less than 3,500 rpm.

This has been made possible by the inclusion of an N63TU2-specific characteristic map for the switching coolant pump in the DME. The heating of the thermocouple is energized depending on the characteristic map. The characteristic map for the N63TU2 engine is determined based on the following parameters:

- Load
- Engine speed
- Vehicle speed
- Intake air temperature
- Coolant temperature

### Components of cooling circuit of exhaust turbocharger

In contrast to the N63TU engine, on the N63TU2 engine a number of modifications were made to the design of the coolant circuit for the exhaust turbocharger.

- The installation location of the electrical auxiliary coolant pump has been changed.
- The connection of the return from the exhaust turbochargers has been relocated.

# N63TU2 Engine

## 4. Cooling

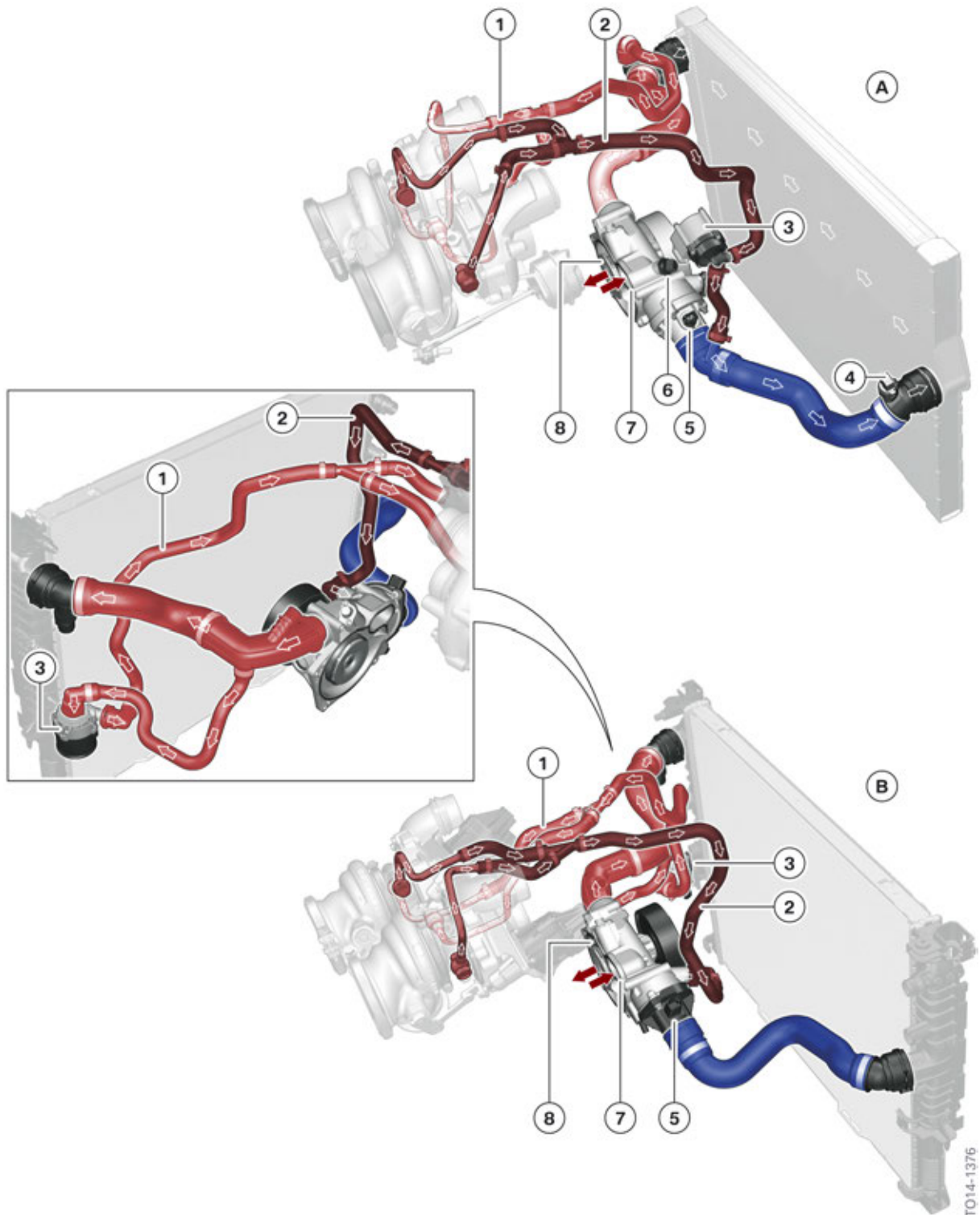

N63TU2 engine, exhaust turbocharger coolant circuit with electrical auxiliary coolant pump

# N63TU2 Engine

## 4. Cooling

Index	Explanation
A	Coolant circuit for exhaust turbocharger on N63TU engine
B	Coolant circuit for exhaust turbocharger on N63TU2 engine
1	Supply line to the exhaust turbochargers
2	Return line from the exhaust turbochargers to the auxiliary water pump
3	Electric auxiliary water pump
4	Coolant temperature sensor at radiator outlet
5	Data-map thermostat
6	Coolant temperature sensor at engine outlet
7	Return of the heated coolant from the engine housing to the coolant pump housing
8	Supply of the cooled coolant to the engine housing

On the N63TU engine, the return of the exhaust turbocharger cooling was integrated into the supply to the radiator via the suction auxiliary coolant pump. This configuration meant that a significant portion of the heat required for a faster warm-up was lost via the radiator.

On the N63TU2 engine, the electrical auxiliary coolant pump is integrated into the supply of the exhaust turbocharger coolant circuit in the form of a pressure pump. The connection of the return from the exhaust turbochargers was relocated to the thermostat housing in front of the thermostat main disc.

This arrangement of components allows the waste heat of the exhaust turbochargers to also be used to heat up the N63TU2 engine more quickly during the warm-up phase via the mechanical coolant pump and stopped electrical auxiliary coolant pump.

This arrangement also provides other benefits:

- More even, faster heating of the exhaust turbochargers.
- Dynamic heat transfer between the exhaust turbocharger, coolant and engine oil, thereby reducing carbon dioxide emissions.
- Reduced thermal stresses for the exhaust turbocharger and electrical auxiliary coolant pump.
- Easier filling and bleeding of the cooling system, in particular for the raised exhaust turbochargers over the mechanical coolant pump.

As the mechanical coolant pump is driven by a belt, it cannot be used to cool the exhaust turbochargers after the engine has shut down. For this reason there is an electric auxiliary coolant pump, which works at a power of 15 W, for this cooling circuit. Whilst the engine is operating, the electric auxiliary coolant pump is activated as from 93° C taking into account the coolant temperature at the engine outlet.



# N63TU2 Engine

## 4. Cooling

The after-run of the electric auxiliary coolant pump can last up to 30 minutes for a stationary engine and when the ignition is turned off. This is calculated on account of the following values:

- Engine oil temperature
- Injected fuel quantity
- Intake air temperature
- Exhaust-gas temperature
- Fuel temperature

The after-run of the electric fan can last up to 11 minutes.

Another function of the electrical auxiliary coolant pump is to support the mechanical coolant pump. During the warm-up phase, the electric coolant pump supports the circulation of coolant in the cooling system. This additional circulation supports the heat transfer between the exhaust turbocharger, coolant and oil and thus reduces the warm-up phase. Further support is provided by the electrical auxiliary coolant pump in what is known as the hot-idling mode phase. In idle mode, the coolant passages of the mechanical coolant pump may not be sufficient to adequately cool the engine via the radiator during the cooling-down period when the engine is at operating temperature. In this operating range, the electrical auxiliary coolant pump supports the coolant passages through the radiator in addition to the mechanical coolant pump.



---

The cooling system (high-temperature coolant circuit) can be filled using the familiar vacuum filler device. Alternatively, the system can be filled using the standard procedure of adding the coolant via the expansion tank using the filler jug. However, in the process it must be ensured that the exhaust turbochargers are ventilated by pressing the accelerator to over 3,500 rpm in a controlled manner. For details of other approved ventilation methods, please see the repair instructions in the ISTA workshop information system.

---

### 4.1.2. Cooling circuit of charge air cooler and DME

For charge air cooling, the system again makes use of so-called **"indirect"** charge air cooling, which is cooled by a separate coolant circuit, the so-called **"low-temperature circuit"**.

An electric coolant pump is used for the coolant circuit of the charge air coolers and DME control units with an independent cooling system. The coolant circuit for the charge air cooling and Digital Motor Electronics (DME) contains a cross-passages radiator and 2 indirect charge air coolers.

# N63TU2 Engine

## 4. Cooling

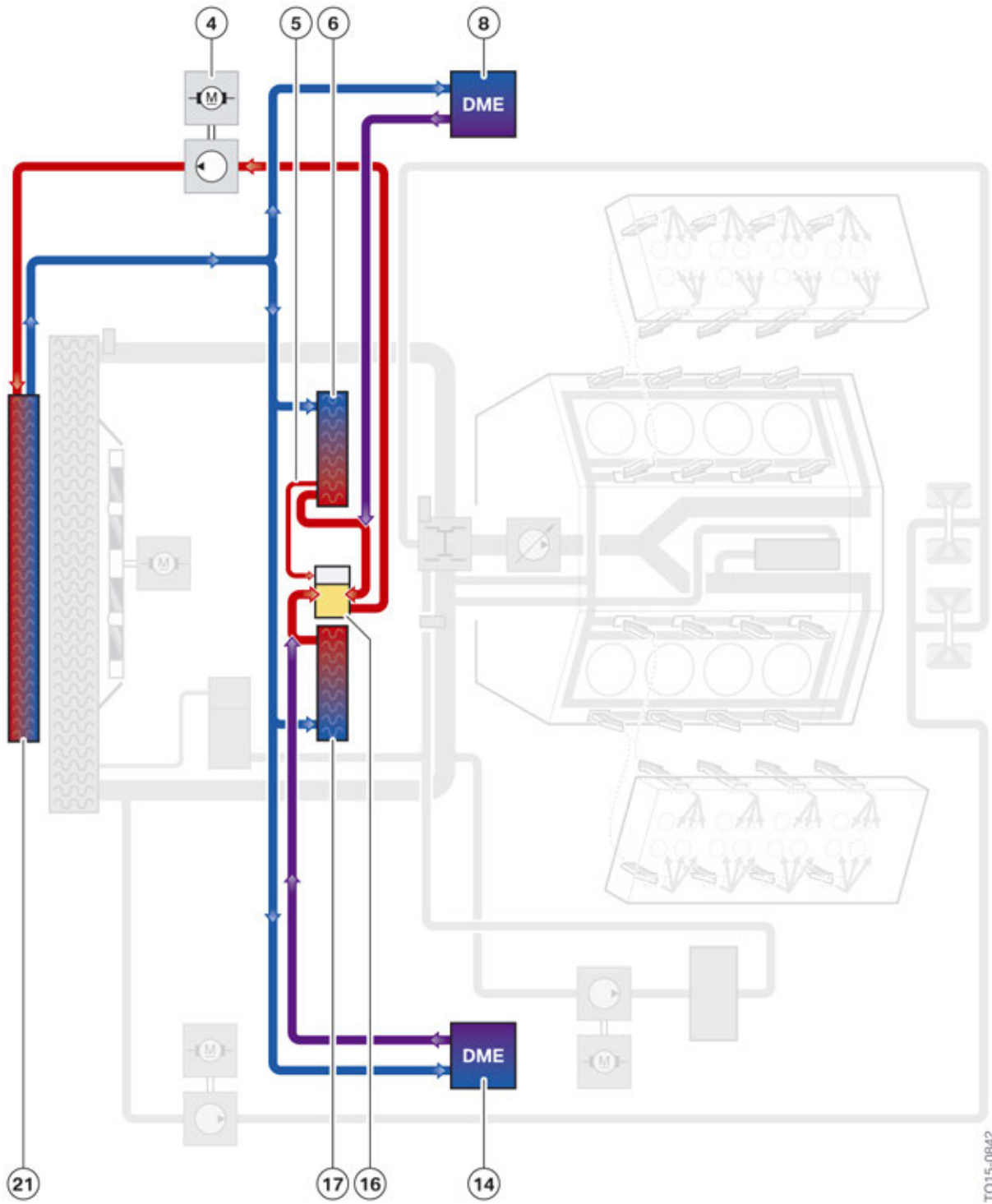

TO15-0842

N63TU2 engine, cooling circuit of charge air cooling with DME

# N63TU2 Engine

## 4. Cooling

Index	Explanation
4	Electric coolant pump for the cooling circuit of the charge air and DME
5	Ventilation line for charge air cooling
6	Charge air cooler, bank 1
8	Digital Motor Electronics (DME) 1
14	Digital Motor Electronics (DME) 2
16	Coolant expansion tank, charge air and DME
17	Charge air cooler, bank 2
21	Cross-passages cooler for the cooling circuit of charge air and DME

### Components of the cooling circuit of charge air cooling with DME

The 80 W pump has a self-diagnosis function and dry-run protection. If the engine speed is increased by 15 minutes over a period, the auxiliary water pumps are switched off and a fault code is stored in the DME. The expansion tank does not have a coolant level switch and does not automatically detect when the fluid level is too low.

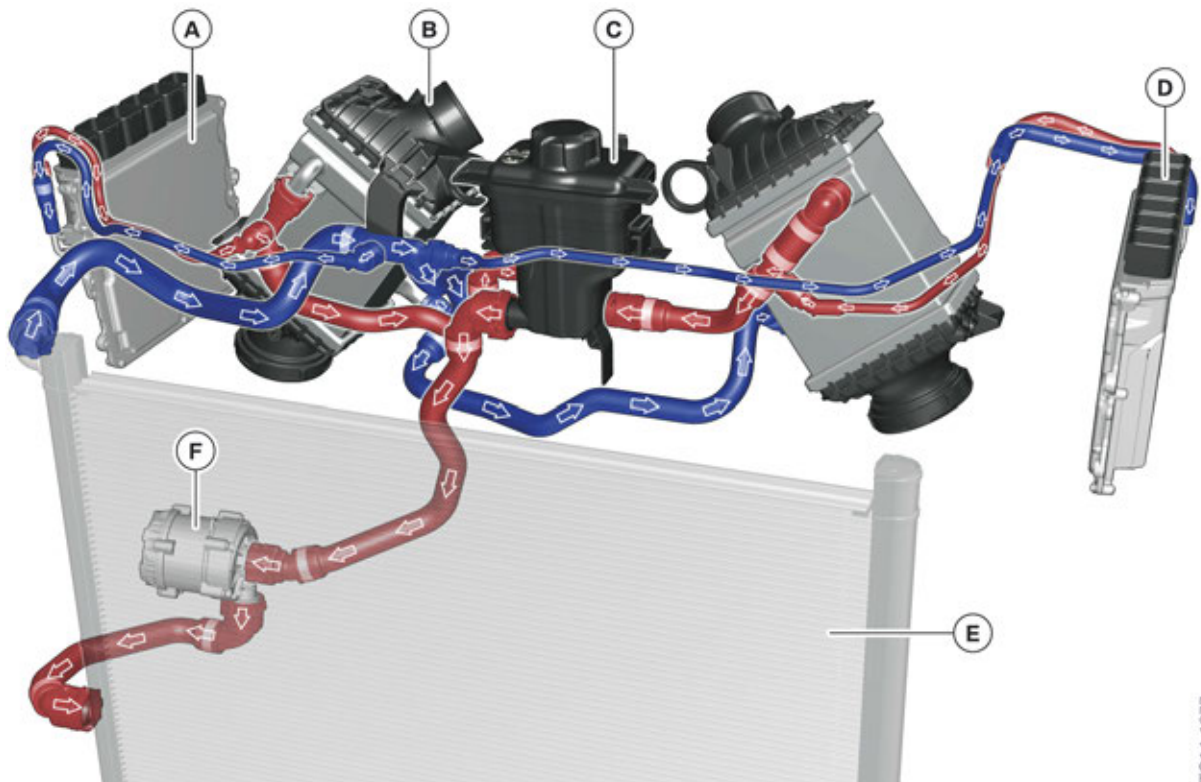

N63TU2 engine, components of cooling circuit of charge air with DME, ECE version

T014-1377

# N63TU2 Engine

## 4. Cooling

---

Index	Explanation
A	Digital Motor Electronics (DME) 1
B	Charge air cooler
C	Expansion tank
D	Digital Motor Electronics (DME) 2
E	Cross-passages cooler for the cooling circuit of charge air and DME
F	Electric coolant pump for the cooling circuit of the charge air and DME

---

### Charge air cooler

The charge air coolers have been reduced in size (dimensions), but still deliver the same performance data as for the N63B44O1 engine to the greatest possible extent.

- Charge air cooler temperature input: approx. 110 °C / 230 °F
- Charge air cooler temperature output: approx. < 50°C / < 122 °F
- Charging pressure: approx. 2,5 bar
- Pressure loss through charge air cooler: approx. 11 mbar

This has been made possible with optimized charge air and coolant conduction in the charge air cooler, which has a positive impact on the loss of pressure and the charge air cooling in the charge air cooler. The system supplier of the new charge air coolers is Delphi.



---

For details of the workflows for filling and bleeding the low-temperature coolant circuit, please see the repair instructions in the ISTA workshop information system.

---

## 4.2. Heat management

The N63TU2 engine comes with extensive heat management functions, controlled or supported by characteristic maps in the Digital Motor Electronics (DME). This comprises independent control of the electric cooling components of electric fan, map thermostat and coolant pumps.

### 4.2.1. Auxiliary water pump

The N63TU2 engine also has a total of 3 other electrical auxiliary coolant pumps in addition to the mechanical coolant pump:

- for heating the interior
- for cooling the exhaust turbochargers
- for cooling the charge air coolers and the two control units of the Digital Motor Electronics.

The electric coolant pump for the cooling circuit of the charge air with DME has a power of 80 W. The two others work at a power of 15 W.

# N63TU2 Engine

## 4. Cooling



---

If the coolant pump is removed and then to be reused, it is important to ensure that it is set down still filled with coolant. Drying out may cause the bearing positions to stick. The upshot of this is that the coolant pump may possibly not start, which in turn may result in engine damage.

Before installing, turn the impeller manually to ensure that it moves freely.

---

### 4.2.2. Data-map thermostat

The N63TU2 engine is equipped with a characteristic map thermostat with travel sensor and return passages barrier.

The function of the characteristic map thermostat is the same as on the N63TU. When not electrically controlled, the technical data of the thermostat is as follows:

- Opening start at 105 °C / 221° F
- Complete opening at 120 °C. / 248°F

In addition, an electric heater in the map thermostats can be used to make the thermostat open already at a lower coolant temperature.

# N63TU2 Engine

## 4. Cooling

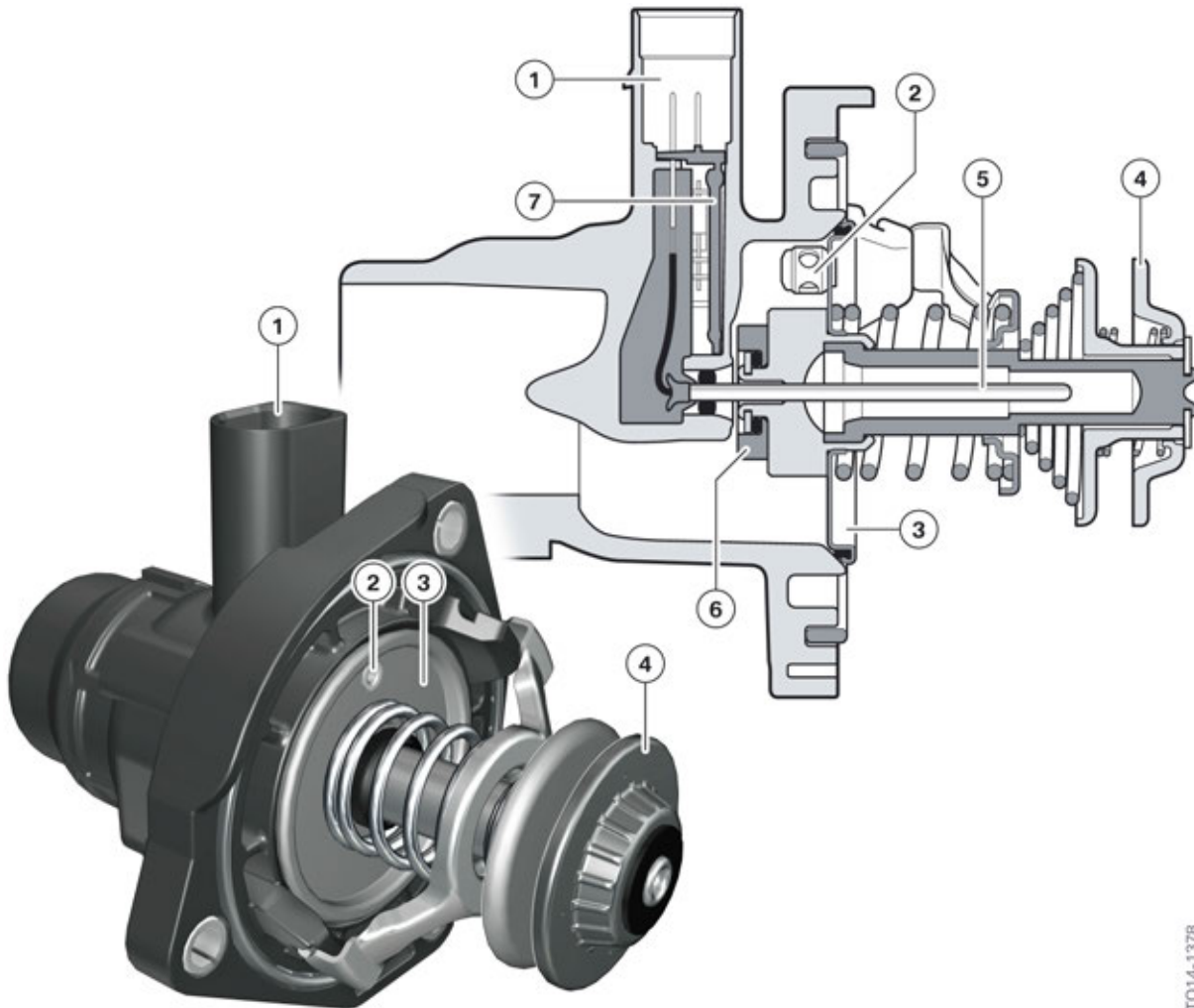

TO14-1378

N63TU2 engine, thermostat

Index	Explanation
1	Electrical connection
2	Vent valve
3	Thermostat main disc
4	Return passages barrier
5	Thermocouple with electrical heating
6	Neodymium magnet for travel sensor
7	Hall effect sensor for travel sensor

# N63TU2 Engine

## 4. Cooling

### Travel sensor

In order to meet more stringent requirements from emissions legislation and to increase the reliability of the cooling system, the characteristic map thermostat was fitted with an opening detection function. As a result, it is now possible to monitor the opening function and thus detect a malfunction in the thermostat (OBD emission monitoring), including via diagnosis.

A hall effect sensor monitors the opening status. The neodymium magnet required for the hall effect sensor is attached to the thermocouple rod. When opening the thermostat, the opening status of the main disc relative to the closing point can be accurately measured on the basis of the strength of the magnetic field and the resulting voltage.

The electronic components are fully insulated from the coolant and are cast in an epoxy resin material.

The travel sensor in the characteristic map thermostat allows the following OBD-relevant functional problems to be recorded:

- **Thermostat jams open.** Can even be recorded before the engine starts (no emissions). (Relevant to OBD emission monitoring)
- **Thermostat does not open.** Can be detected much sooner and the risk of overheating can be prevented.

Previous experience with the indirect thermostat diagnosis, which is based on the medium temperature (coolant) and is used in the N63TU engine, has shown it to be inaccurate. As a result, it no longer meets current requirements as stipulated by the emission monitoring (OBD). Additionally, thanks to the monitoring and the diagnostic capability of the characteristic map thermostat, unnecessary replacement of thermostats is avoided.



---

As the travel sensor is a linear hall effect sensor, a resistance measurement for checking the sensor is not permitted.

---

### Return passages barrier

The return passages barrier takes the form of an additional valve head on the thermostat. When the engine (and thus also the mechanical coolant pump) are switched off, this valve head closes the short-circuit cross section between the engine outlet and thermostat mixing chamber. However, the thermostat mixing chamber simultaneously acts as the suction chamber for the electrical auxiliary coolant pump for the exhaust turbochargers.

# N63TU2 Engine

## 4. Cooling

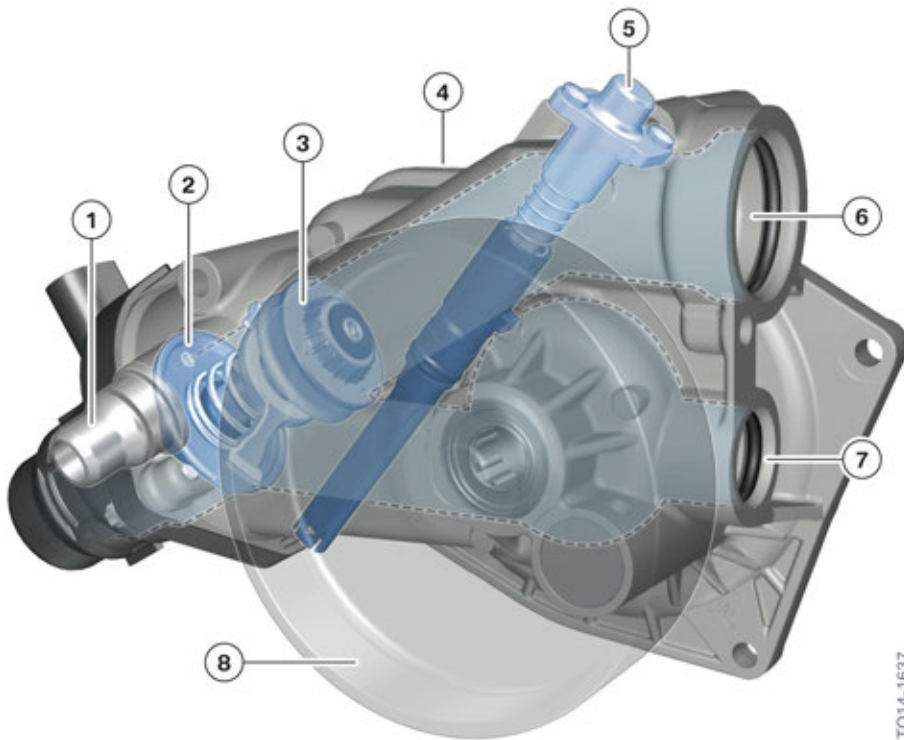

N63TU2 engine, coolant pump with thermostat

Index	Explanation
1	Coolant return, exhaust turbocharger
2	Thermostat main disc
3	Return passages barrier
4	Coolant return, bank 1 and 2
5	Thermal actuator with electrical heating element
6	Supply to radiator/removal of coolant for heating and exhaust turbocharger
7	Heating return
8	Belt pulley



# N63TU2 Engine

## 4. Cooling

The return passages barrier influences the following 2 coolant circuits.

### **Heating in vehicle interior**

If the return passages barrier were not fitted, when the engine is at operating temperature or stopped the electric coolant pump would always pump the same coolant to supply the heat exchanger for the heating system. This is because the coolant would always take the path of least resistance. The path of the coolant would then always rotate as follows:

- Coolant pump feed line
- Electric coolant pump for heating
- Feed line to heat exchanger for the heating system
- Heat exchanger
- Return line of the heat exchanger for the heating system to coolant pump feed line

As a result, the coolant cooled down by the heat exchanger for the heating system is always supplied to the heat exchanger for the heating system again. This would quickly lead to a noticeable reduction in heater output in the interior.

# N63TU2 Engine

## 4. Cooling

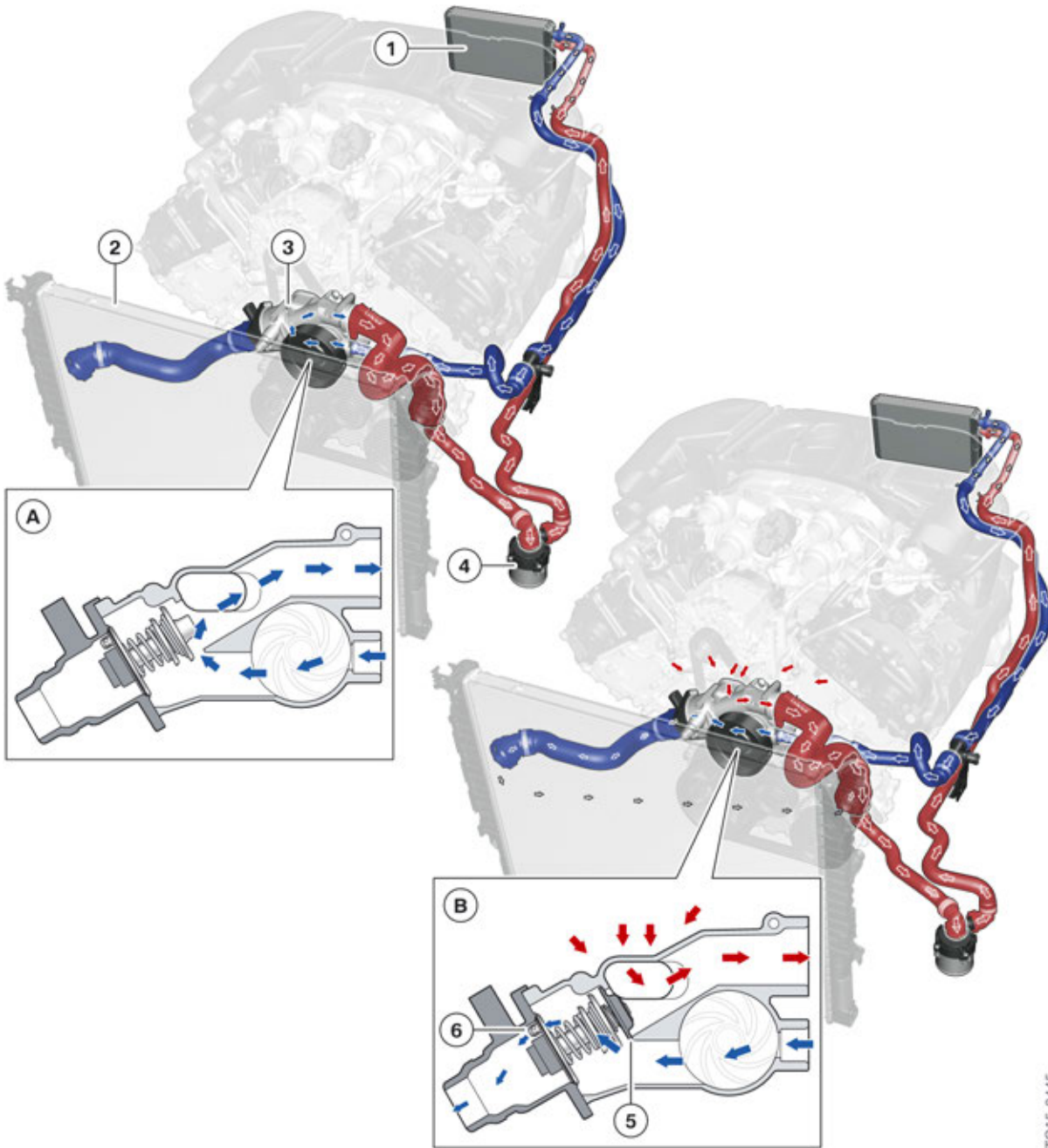

TO15-0445

N63TU2 engine, return passages barrier for heating

Index	Explanation
A	Heating coolant passages without return passages barrier
B	Heating coolant passages with return passages barrier
1	Heat exchanger
2	Radiator

# N63TU2 Engine

## 4. Cooling

Index	Explanation
3	Coolant pump
4	Electric auxiliary coolant pump for vehicle heating
5	Return passages barrier
6	Vent valve

This is prevented by the return passages barrier as it closes this path of least resistance. As a result, the electric coolant pump always draws the coolant (at operating temperature) required for heating from the crankcase and cylinder head. The coolant – which is at operating temperature and available in a larger quantity in the cylinder head and crankcase – therefore ensures that the heating can be maintained for longer. This measure means, for example, that the engine can be stopped for longer by the automatic engine start-stop function (MSA) without a start request being sent from the integrated automatic heating/air conditioning system (IHKA) to the automatic engine start-stop function (MSA). In turn, this possibility to stop the engine for longer by the automatic engine start-stop function (MSA) allows fuel to be saved and carbon dioxide emissions to be reduced.

# N63TU2 Engine

## 4. Cooling

### Exhaust turbocharger cooling

The return passages barrier is also active during the after-run if the electrical auxiliary coolant pump is used to cool the exhaust turbochargers when the ignition is switched off.

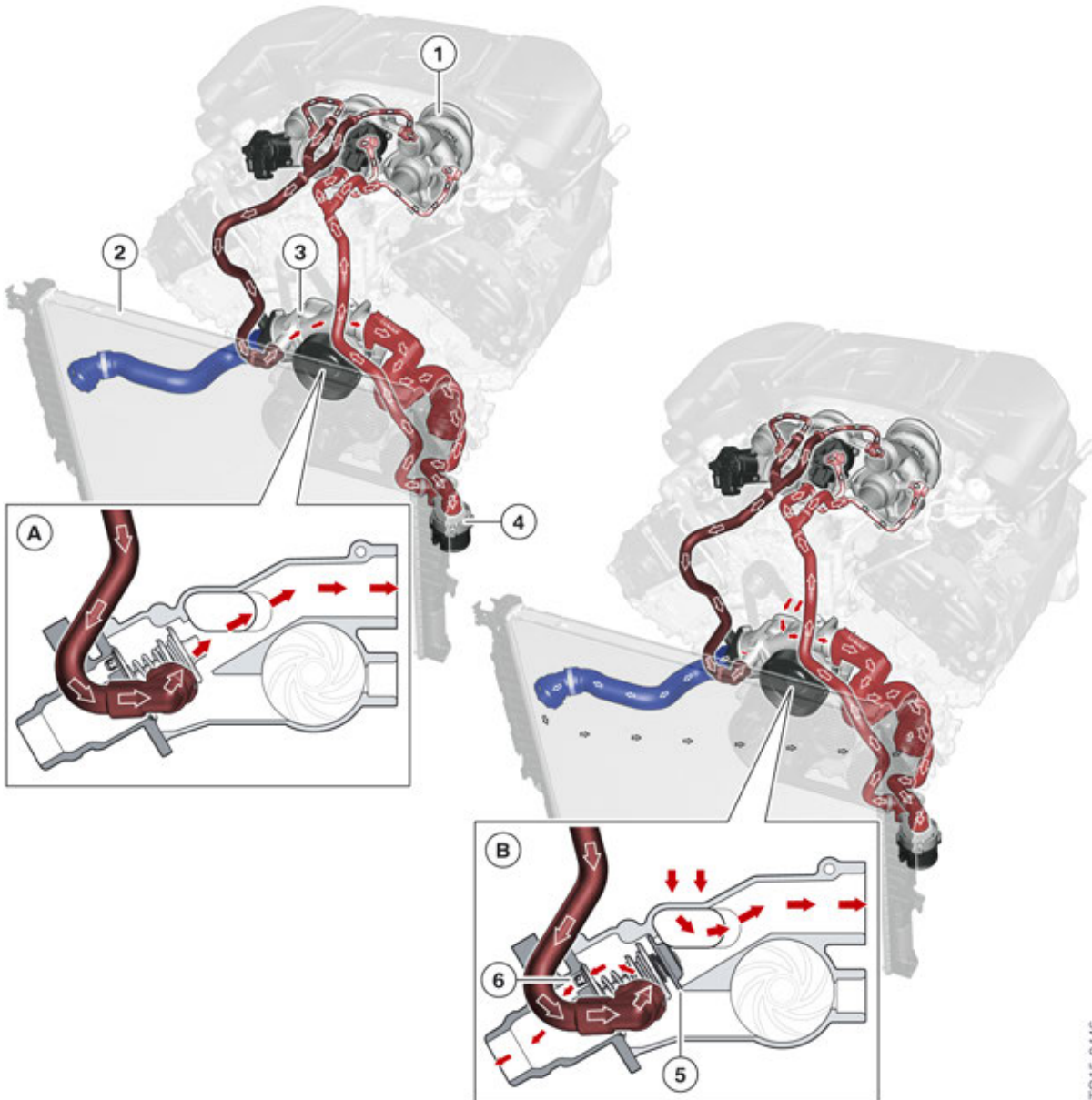

TO15-0446

N63TU2 engine, return passages barrier for exhaust turbocharger cooling

# N63TU2 Engine

## 4. Cooling

Index	Explanation
A	Coolant passages for exhaust turbocharger cooling without return passages barrier
B	Coolant passages for exhaust turbocharger cooling with return passages barrier
1	Exhaust turbocharger
2	Radiator
3	Coolant pump
4	Electric auxiliary water pump for exhaust turbocharger cooling
5	Return passages barrier
6	Vent valve

During after-run, the return passages barrier prevents the coolant from being constantly pumped to the exhaust turbochargers in a small coolant circuit (bypass), which would result in a difference in temperature between the exhaust turbochargers and the other engine components. The return passages barrier closes the bypass such that the coolant for cooling the exhaust turbochargers is always pumped via the radiator. This ensures that the larger quantity of available coolant (at operating temperature) is used in the radiator circuit to provide more even cooling between the exhaust turbochargers and the rest of the engine components. As a result, the temperature of the exhaust turbochargers can be maintained for longer and is aligned to the other engine components. This rules out negative temperature differences between the individual components.

The return passages barrier does not function during the warm-up phase (when the main disc of the thermostat is closed) or in the cooling-down period (when the thermostat is open). During the warm-up phase (when the bypass is active), the spring force of the return passages barrier is overridden meaning the return passages barrier opens. As is already known, the coolant can then circulate in the small coolant circuit via the open return passages barrier.

# N63TU2 Engine

## 4. Cooling

### 4.2.3. Coolant temperature sensor

The N63TU2 engine uses a new coolant temperature sensor compared with the N63TU. In comparison with the coolant temperature sensor from the N63TU engine, the new coolant temperature sensor has a faster response time as less material is used and the connector system is sturdier. The new installation position allows for even more precise temperature sensing in the N63TU2 engine.

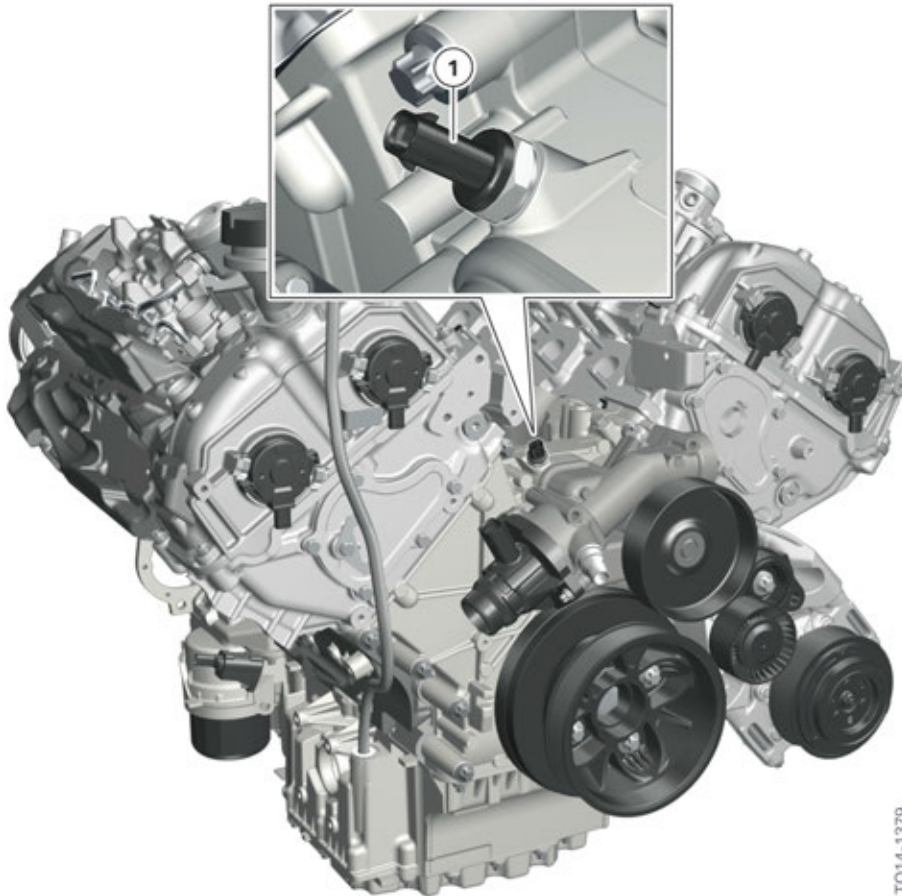

TO14-1379

N63TU2 engine, coolant temperature sensor

Index	Explanation
1	Installation location of coolant temperature sensor

# N63TU2 Engine

## 5. Intake Air and Emission System

The intake and exhaust emission systems are in principle comparable with those in the N63TU engine. The list below itemizes the most important changes to the intake and exhaust emission systems:

- passages-optimized air intake duct with partial integration of the intake pipe into the cylinder head (half-shell intake system).
- Hot film air mass meter 8.
- 4 identical intake air pressure sensors, whereby in the intake pipe only the temperature value is measured, but in the charge air cooler the pressure and temperature values are measured.
- Monitoring sensor changed over to LSF Xfour.
- Exhaust manifold adapted for twin-scroll exhaust turbocharger.
- Use of twin-scroll exhaust turbocharger technology with electrical wastegate valve actuators.
- Use of electrical exhaust flaps in the rear silencer.

### 5.1. Overview

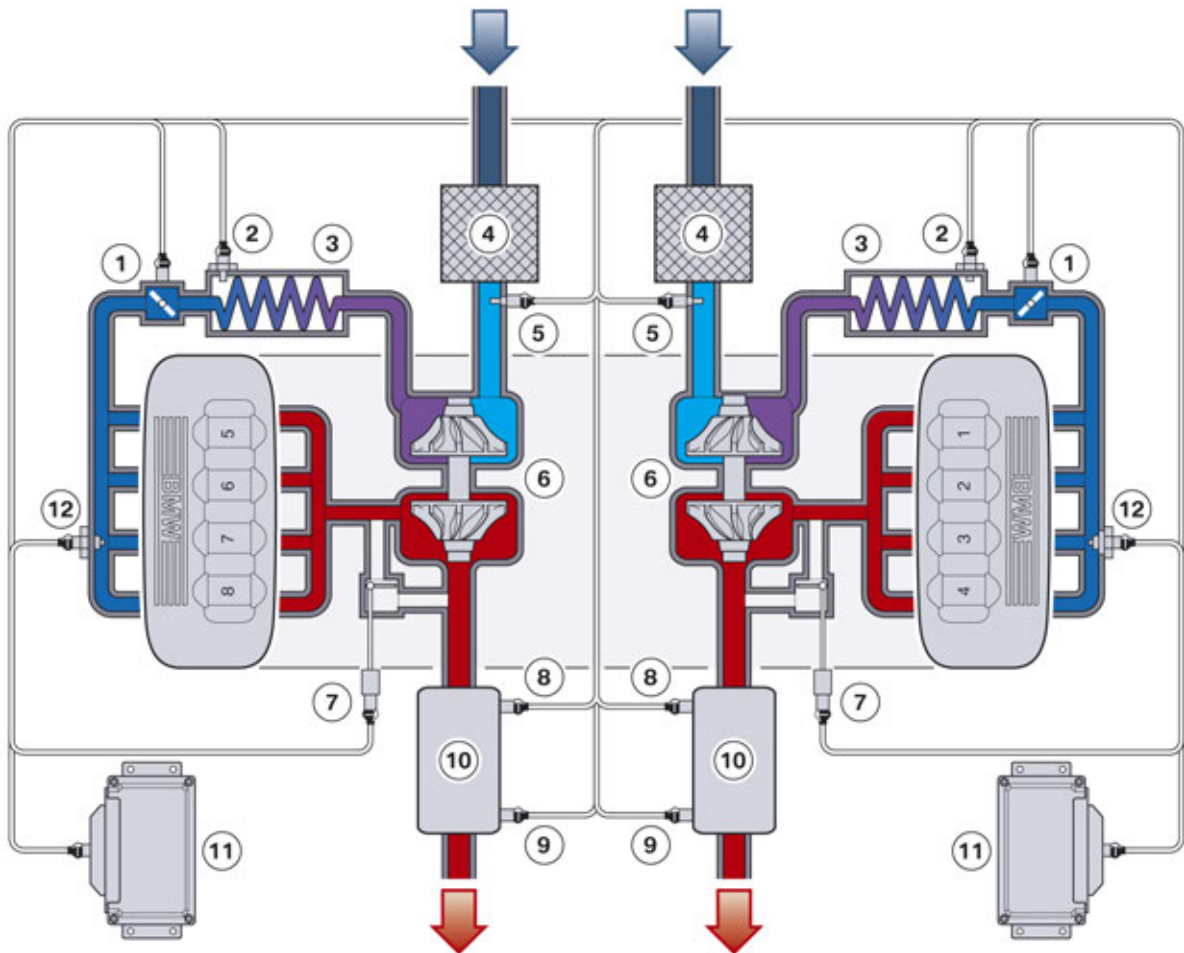

N63TU2 engine, air intake and exhaust emission systems

TO14-1380

# N63TU2 Engine

## 5. Intake Air and Emission System

---

<b>Index</b>	<b>Explanation</b>
1	Throttle valve
2	Charging pressure sensor and temperature sensor
3	Charge air cooler
4	Intake silencer
5	Hot film air mass meter 8
6	Exhaust turbocharger
7	Electrical wastegate valve actuator
8	Oxygen sensor before catalytic converter, control sensor LSU ADV
9	Oxygen sensor after catalytic converter, monitoring sensor, LSF Xfour
10	Catalytic converter
11	Digital Motor Electronics (DME)
12	Charge-air temperature sensor

---



# N63TU2 Engine

## 5. Intake Air and Emission System

### 5.2. Intake air system

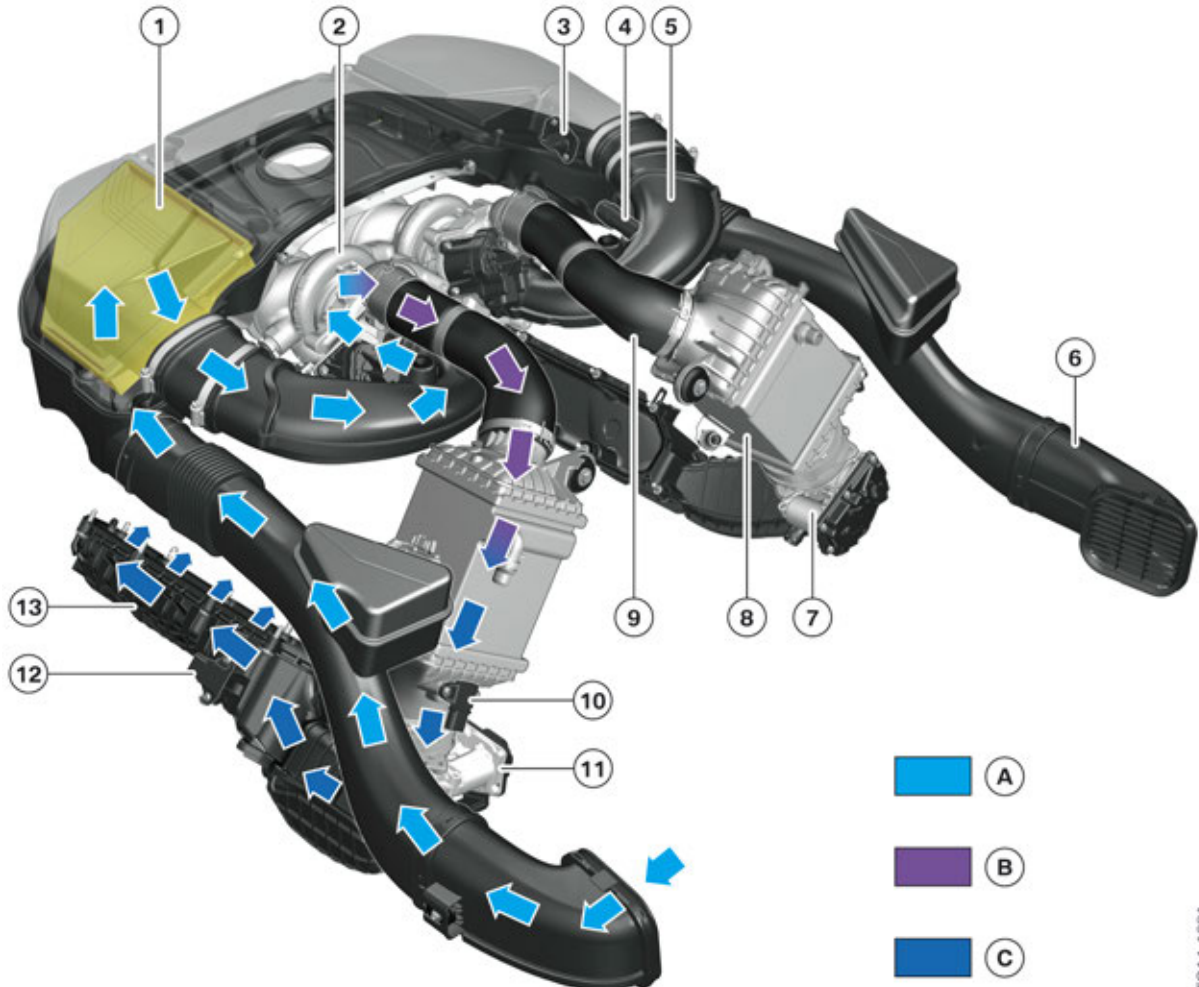

N63TU2 engine, intake air system

Index	Explanation
A	Intake air
B	Compressed, heated charge air
C	Cooled charge air
1	Intake silencer
2	Exhaust turbocharger
3	Hot film air mass meter 8
4	Connection for crankcase ventilation for clean air pipe
5	Clean air pipe
6	Unfiltered air pipe
7	Throttle valve with servomotor

TO14-1381

# N63TU2 Engine

## 5. Intake Air and Emission System

Index	Explanation
8	Charge air cooler
9	Charge air pipe
10	Charging pressure sensor
11	Throttle valve with servomotor
12	Charge air temperature and intake-manifold pressure sensor
13	Intake manifold

### 5.2.1. Hot film air mass meter

The N63TU2 engine is fitted with the hot film air mass meter 8 supplied by Bosch. The hot film air mass meter 8 is already used on modular engines. A direct connection to the DME 8 is established via the SENT interface. The integrated SENT interface reduces the number of access lines on the hot film air mass meter and the DME. Furthermore, the SENT interface allows more data to be transferred even faster and more precisely than with a frequency interface (as was used for the hot film air mass meter 7). This is also advantageous for compliance with future exhaust emission standards.

#### Differences between hot film air mass meter 7 and hot film air mass meter 8

In addition to the new data transfer interface SENT, the main difference between the hot film air mass meter 8 and the predecessor hot film air mass meter 7 is an additional integrated NTC temperature sensor. By integrating the temperature sensor, the sensor element was reduced meaning the aerodynamics of the hot film air mass meter housing could be optimized. The hot film air mass meter 8 also features lower power consumption < 20 mA (hot film air mass meter 7: < 100 mA), its voltage supply has been reduced to 5 V (hot film air mass meter 7: 12 V) and the sensor element has integrated chip heating. The integrated chip heating is used to prevent deposits resulting from dirt particles or oil mist, for example. These can accumulate in particular when the engine is stopped (i.e. no air column movement on the sensor element) and cause inaccurate measurements or even damage. As such, in order to prevent these deposits the hot film air mass meter 8 is switched to chip heating mode in certain situations, such as when the engine is stopped by the automatic engine start-stop function.

#### SENT protocol

##### Single Edge Nibble Transmission

Single Edge Nibble Transmission is a simple digital interface standardized in the automotive industry and used for communication between sensors and control units.

It is a unidirectional, asynchronous voltage interface that requires only three lines: the usual 5 V supply voltage, the signal voltage and the ground connection. The SENT protocol is characterized by its simplicity and resistance to fault signals. Another advantage is that the data is available in digital format in the sensor after the A/D conversion, meaning it can be processed further directly by the control unit.

# N63TU2 Engine

## 5. Intake Air and Emission System



Malfunction or disconnection of the hot film air mass meter does not immediately result in emergency engine operation. However, impaired mixture preparation and therefore poorer emission values are possible, which is why the emissions warning lamp lights up.

### 5.2.2. Intake silencer

The N63TU engine has its own intake silencer for each bank. These are fixed in the vehicle and hold the hot film air mass meters.

### 5.2.3. Intake manifold

The N63TU2 engine uses the newly developed half-shell intake system, which offers a number of advantages. These were realized by partially integrating the components that would otherwise be located in the engine into the cylinder head. Therefore, in the area of the cylinder head the intake system now only consists of an outer shell, which is sealed against the cylinder head using an all-round gasket.

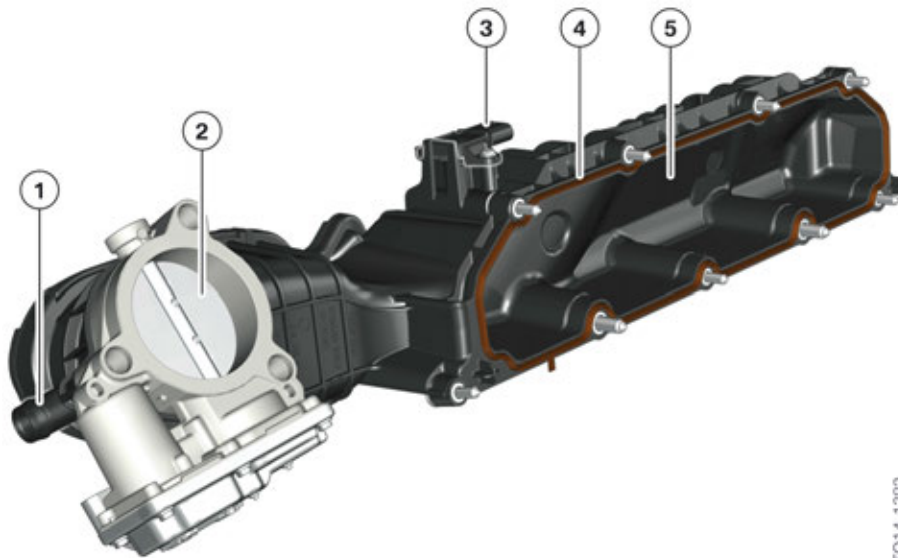

TO14-1382

N63TU2 engine, intake manifold with throttle valve

Index	Explanation
1	Connection from tank vent valve
2	Throttle valve
3	Charge-air temperature sensor
4	All-round gasket
5	Intake manifold

# N63TU2 Engine

## 5. Intake Air and Emission System

Thanks to this new design for the intake system, the intake ports could be enlarged despite a shortening of the intake system. Likewise, the steps between the intake pipe and cylinder head as a result of tolerances were avoided. As such, pressure losses in the intake system were reduced by 6–7% compared with the N63TU engine. A significant amount of installation space was also created by shortening the intake system on the N63TU2 engine, which was made possible by the half-shell design. This newly created space can now be used for other purposes, or alternatively there is the option of using the N63TU2 engine for other vehicle projects.

### 5.3. Exhaust turbocharger

The N63TU2 engine has 2 exhaust turbochargers supplied by Honeywell. The exhaust turbochargers are twin-scroll exhaust turbochargers and, with the exception of the compressor and wastegate valve actuation, were taken over from the S63TU engine. The compressor and impellers were newly designed for the N63TU2 engine and thus adapted to its performance structure. Both exhaust turbochargers are a common part for both banks. As on the N63TU engine, a blow-off valve was dispensed with for this overall concept.

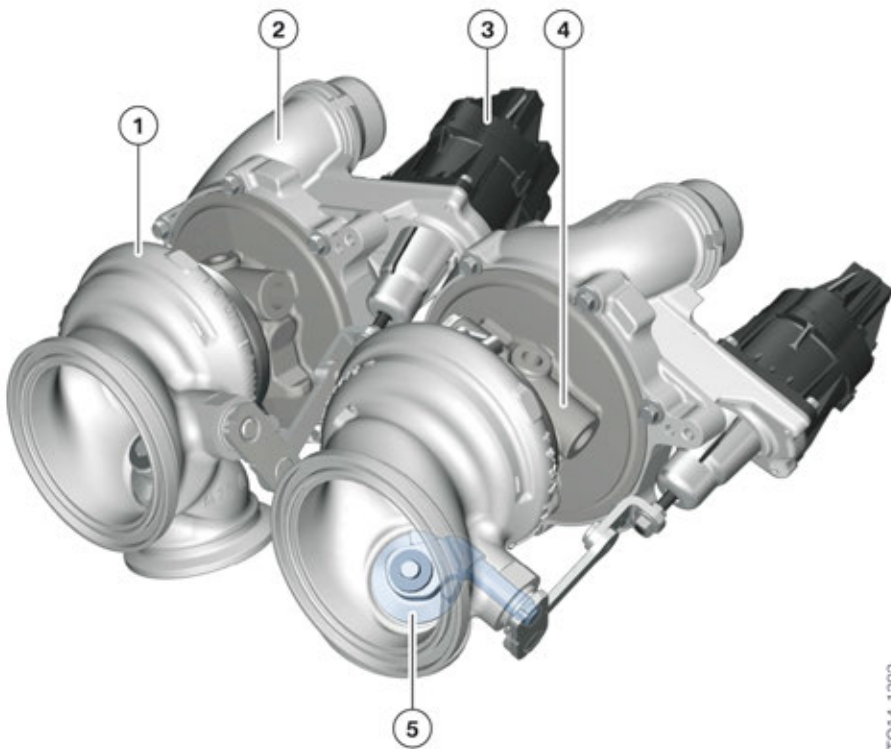

TO14-1383

N63TU2 engine, exhaust turbocharger

Index	Explanation
1	Turbine housing
2	Compressor output
3	Electrical wastegate valve actuator
4	Bearing seat
5	Wastegate valve

# N63TU2 Engine

## 5. Intake Air and Emission System

One-piece wastegate valves are used, increasing robustness.



For assembly precise alignment of the exhaust turbocharger is necessary. Please strictly observe the repair instructions.

### 5.3.1. Charging pressure control

An electrical wastegate valve actuator controls the charging pressure control on the N63TU2 engine.

#### Electrified adjustment

In contrast to a vacuum-controlled charging pressure control, the following components are not required:

- Vacuum unit
- Vacuum lines
- Electro-pneumatic pressure converter
- Vacuum reservoir

#### Advantages of electrical activation

- Faster control speed
- More precise control
- Simpler diagnosis
- Fewer components
- Larger opening angle of wastegate valve

#### Operating principle

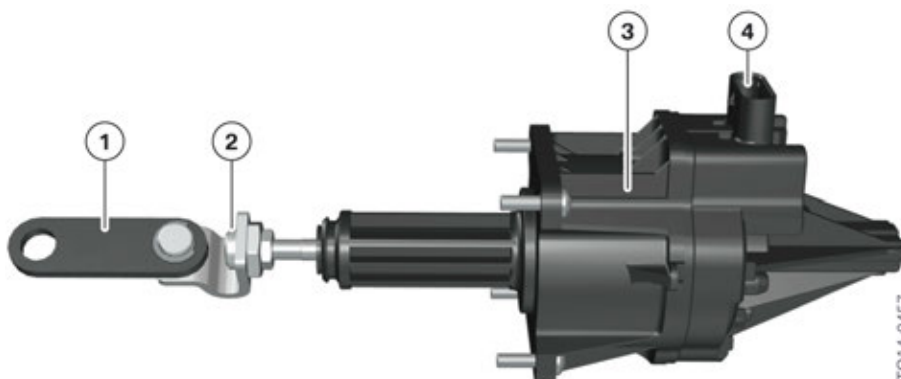

N63TU2 engine, electrical wastegate valve actuator

# N63TU2 Engine

## 5. Intake Air and Emission System

---

Index	Explanation
1	Stroke linkage
2	Adjusting linkage
3	Actuator
4	Electrical connection

---

A direct current motor and a sensor are located in the electrical wastegate valve actuator, resulting in a total of 5 electrical connections on the component. The wastegate valve is opened or closed by a lifting movement of the linkage.

The electrical wastegate valve actuator can be replaced separately during a service. Each time the adjusting linkage is activated, the system must be re-adjusted with the assistance of the BMW diagnosis system ISTA. This measure is not required when replacing the entire exhaust turbocharger as the linkage is supplied preset.



---

If the electrical wastegate valve actuator is replaced individually, a teach-in routine must be performed using the BMW diagnosis system ISTA.

---

The sensor is used to determine the position of the wastegate valve. The wastegate valve can move to any required position between maximum open and maximum closed. When the sensor signal or actuator drops out, the wastegate valve adopts the open position to allow charging pressure to build up. This ensures the journey continues with reduced engine performance.



---

As the position sensor is a linear Hall sensor, a resistance measurement for testing the sensor is not permitted.

---

### 5.3.2. Function

The blow-off valves at the exhaust turbocharger are discontinued for this overall concept as their job is effectively replaced by the engine interventions. The feasibility was supported by the use of an optimized compressor which permits a more stable pump design in comparison to the predecessor compressor.

Reasons for the installation of a blow-off valve to date were:

- Avoidance of pump for load shedding (transition from traction to coasting/overrun mode).
- Possible pumping causes pulsating, acoustic interference noise.
- Arising pressure waves as a result which burden the thrust bearing of the exhaust turbocharger.

# N63TU2 Engine

## 5. Intake Air and Emission System

In the case of load shedding without a blow-off valve the aim is to avoid a compressor pump. A pumping compressor arises if high pressure ratios and low mass flows occur. In contrast the engine measures are that through the engine control the target mass passages is increased until the pump limit can fall below the limit and the charging pressure can dissipate. The necessary mass passages is adjusted by activating the throttle valve and valve lift. Excessive cylinder filling and the resulting high torque is then torque-controlled for example reduced via an ignition timing adjustment in retarded direction.

### 5.4. Exhaust emission system

#### 5.4.1. Exhaust manifold

The exhaust manifold of the N63TU2 engine is manufactured from cast steel using foam casting.

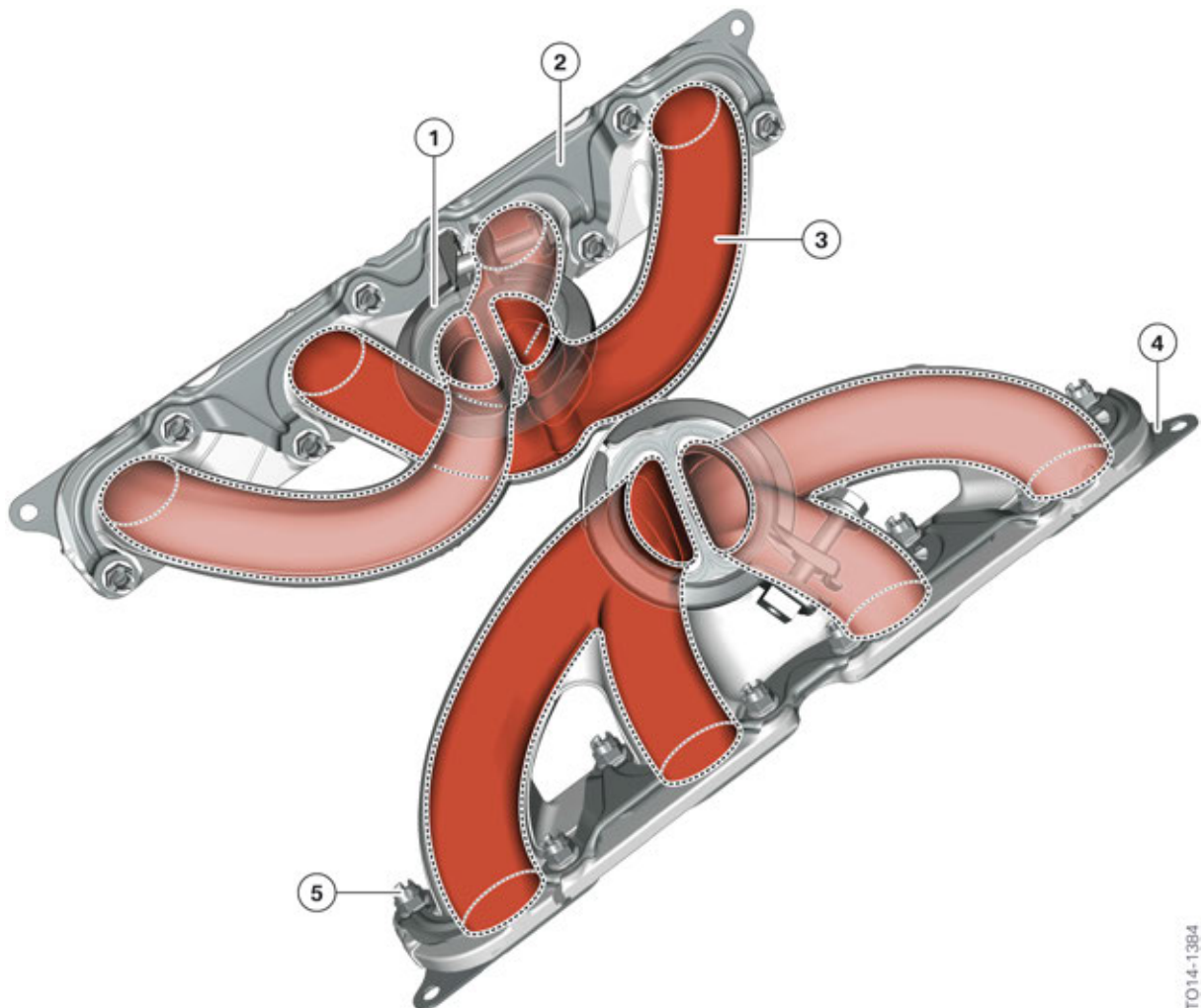

N63TU2 engine, exhaust manifold

TO14-1384

# N63TU2 Engine

## 5. Intake Air and Emission System

Index	Explanation
1	Exhaust manifold
2	Slide rail
3	Combined exhaust flows
4	Beaded metal gasket
5	Nut

To ensure that the exhaust flows combine, which is required for a twin-scroll exhaust turbocharger to work, the furthest apart igniting exhaust flows were combined on the cylinder bank side. As a result, the N63TU2 engine has a bank-specific exhaust manifold for cylinder banks 1 and 2. On the exhaust manifold for bank 1 exhaust flows 1–3 and 2–4 were combined; for cylinder bank 2 the exhaust flows of cylinders 5–6 and 7–8 were combined.

### 5.4.2. Catalytic converter

The N63TU2 engine has one catalytic converter per bank. The outlet hoppers are now single-walled. The catalytic converter near the engine comprises a 1st and a 2nd monolith. The catalytic converters have decoupling elements which are also described as expansion elements.

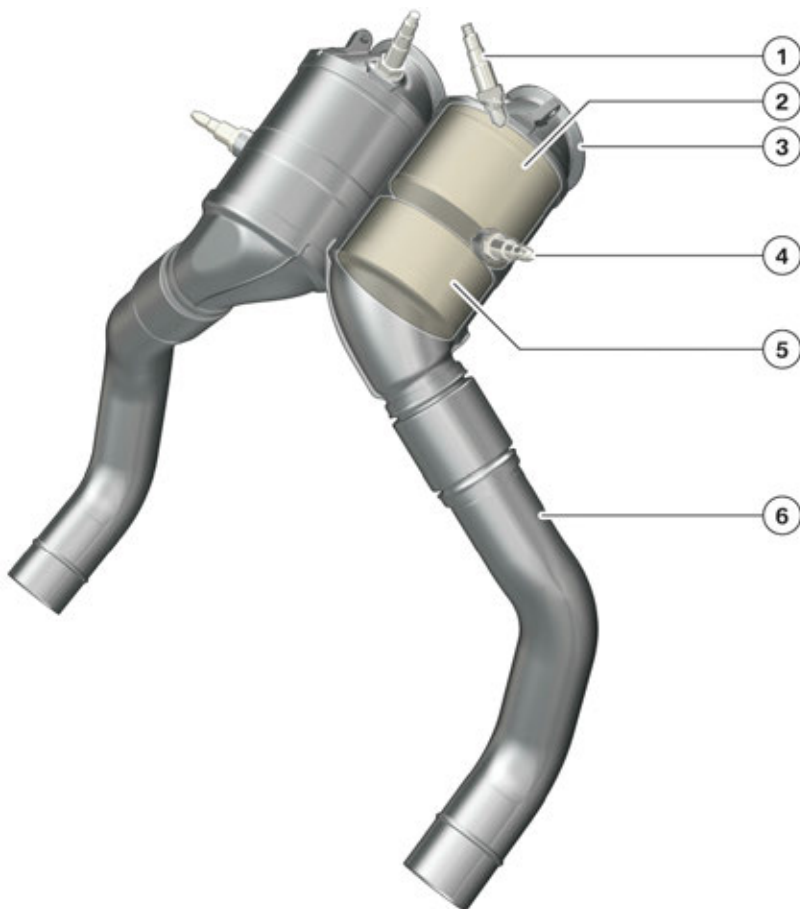

TO14-1385

N63TU2 engine, sectional view of the catalytic converter



# N63TU2 Engine

## 5. Intake Air and Emission System

Index	Explanation
1	Control sensor
2	Ceramic monolith 1
3	Connection of the turbine
4	Monitoring sensor
5	Ceramic monolith 2
6	Exhaust pipe

### Exhaust emission system

3-way catalytic converter	2-monolith system
Cell density of ceramic monolith 1 *	600 *
Cell density of ceramic monolith 2	400

\* In the China version, a modified 3-way catalytic converter is used due to the high manganese content of the fuel (2-monolith system, cell density 400/400).

### Oxygen sensor before catalytic converter

The oxygen sensor (LSU ADV) from Bosch is used as a control sensor before the catalytic converter. The function is comparable to the oxygen sensor (LSU 4.9) and therefore is not described in detail here. This oxygen sensor is already used in the N63TU engine. The abbreviation LSU stands for universal oxygen sensor and ADV for Advanced.

The oxygen sensor before catalytic converter (LSU ADV) is characterized by the following advantages:

- High signal running, especially in charged operation due to lower dynamic pressure dependence.
- Increased durability thanks to reduced pump voltage.
- Improved precision (vis-a-vis LSU 4.9 by 1.7).
- Faster operating readiness < 5 s.
- Increased temperature compatibility.
- Improved system connector with better contact properties.

The LSU ADV has an extended measuring range. It is thus possible to measure precisely from oxygen sensor 0.65. The new oxygen sensor is operational earlier, meaning exact measured values are available after only 5 s.

The measuring dynamics of the sensor is higher, whereby it is possible to determine the air/fuel ratio in each cylinder separately and thus also control it. As a result, a homogeneous exhaust passages can be adjusted, the emission levels lowered and the long-term emission behavior optimized.

# N63TU2 Engine

## 5. Intake Air and Emission System

### Oxygen sensor after catalytic converter

The oxygen sensor after catalytic converter is also called a monitoring sensor. The monitoring sensor LSF XFOUR from Bosch is used which is the successor sensor to the LSF 4.2.

The LSF Xfour needs the DME 8.8 for signal evaluation and is characterized by the following properties:

- In order to achieve faster response characteristics after the engine has started (halved compared with the LSF 4.2), a heater with a greater degree of regulation has been integrated into the LSF Xfour.
- This improves signal stability.
- Less space is required for installation.
- Thanks to the high temperature resistance and optimal thermo-shock protection, the resistance to condensation in the exhaust tract following a cold start has been improved.

The control sensor is located ahead of the 1st ceramic monolith, as close as possible to the turbine outlet. Its position has been chosen so that all the cylinders can be recorded separately. The monitoring sensor is positioned between the 1st and 2nd ceramic monoliths.

### 5.4.3. Exhaust system

#### Main differences in the exhaust system of the N63TU2 compared with the N63TU

- Pneumatic exhaust flaps replaced by electrical exhaust flaps.

The exhaust system on the N63TU2 engine for the 12 consists of:

- 1 shell front silencer with a volume of 5 liters.
- 1 shell center silencer with a volume of 5 liters.
- 1 shell rear silencer with a volume of 38 liters.
- 2 twin tailpipes with tailpipe trim attached to the body.

# N63TU2 Engine

## 5. Intake Air and Emission System

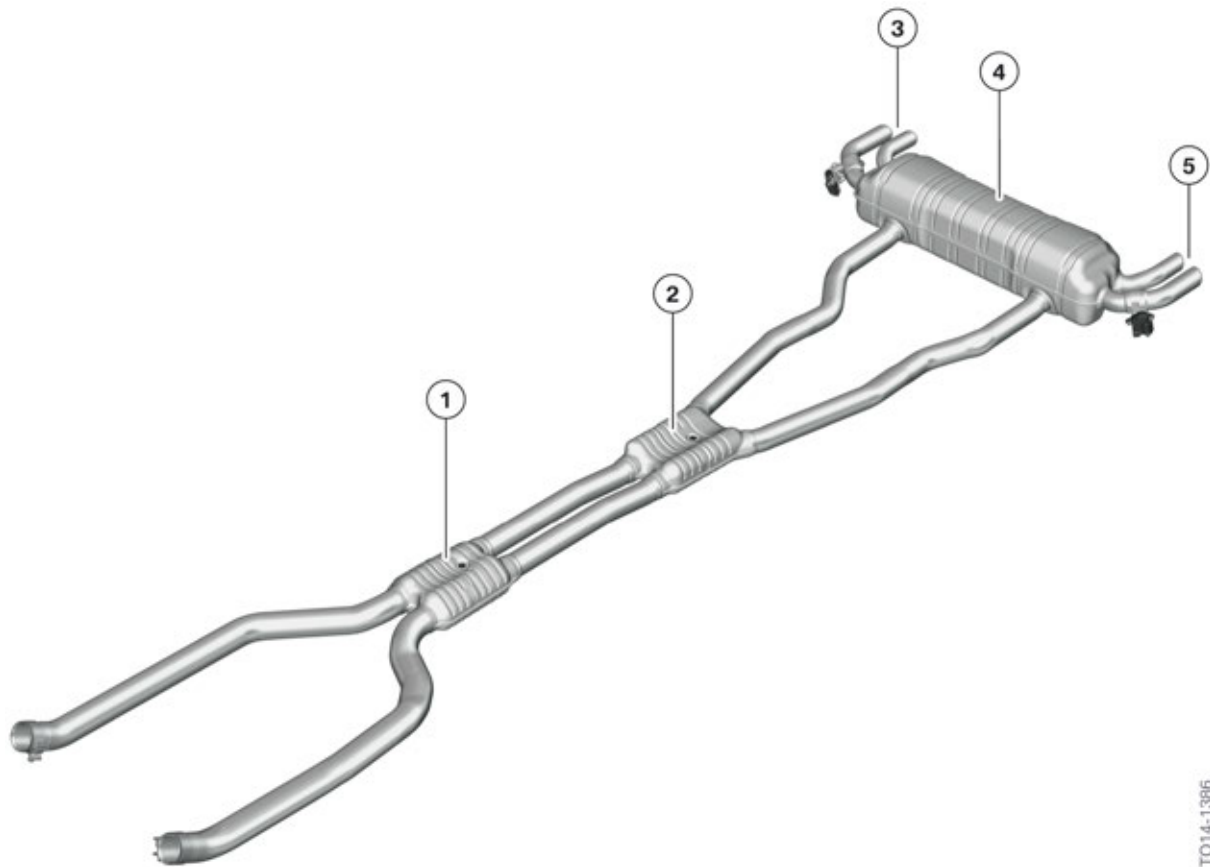

TO14-1386

N63TU2 engine, exhaust system

Index	Explanation
1	Front silencer
2	Center silencer
3	Twin tailpipe, right
4	Rear silencer
5	Twin tailpipe, left

On the N63TU2 engine, the pneumatic exhaust flap controller has been replaced with an electrical exhaust flap controller.

# N63TU2 Engine

## 5. Intake Air and Emission System

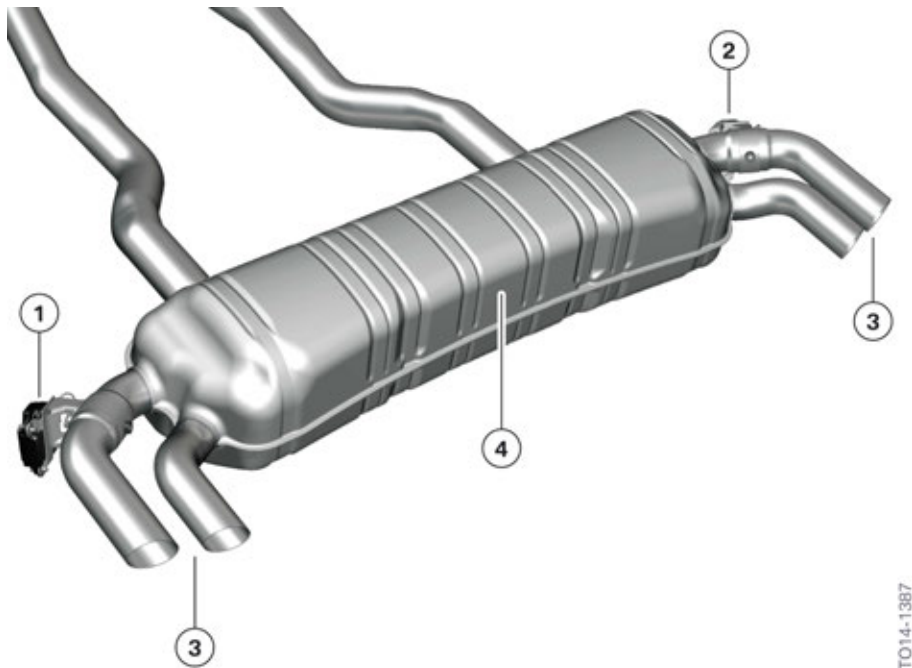

N63TU2 engine, exhaust flap controller

TO14-1387

Index	Explanation
1	Electrical exhaust flap actuator (EAKS), left
2	Electrical exhaust flap actuator (EAKS), right
3	Twin tailpipe
4	Rear silencer

### 5.4.4. Electrically controlled exhaust flaps

#### Electrically controlled exhaust flap(s)

The exhaust flap is integrated into the rear silencer. The exhaust flap is operated by an axially arranged electric motor with integrated gears and electronics. The electrical controller for the adjustable exhaust flap has the following electrical connections:

- Voltage supply (+)
- Ground (-)
- Actuating wire (signal line)

At low engine speeds and low loads, the noise level can be significantly reduced by closing the exhaust flap. At high engine speeds and high loads, the exhaust gas counterpressure can be reduced by opening the exhaust flap.

# N63TU2 Engine

## 5. Intake Air and Emission System

The exhaust flap is activated (using pulse width modulation) by the Digital Motor Electronics (DME). The input variables are:

- Engine speed
- Load
- Driving speed

The exhaust flap cannot adopt an intermediate setting; it is either fully opened or closed. The flap moves towards the respective mechanical end stop using pulse-width modulated signals (PWM signals). If faults are detected or the actuation stops, or after the engine has been stopped, the preferred position is the closed position. On vehicles with the M Sport exhaust system, the exhaust flap is open in Sport mode.

Electrical exhaust flap	N63TU2
Installation location	right and left
PWM signal open	10% duty cycle
PWM signal closed	90% duty cycle



The controller of the electrical exhaust flap can be replaced separately. The controller can be moved into an installation position using the BMW diagnosis system ISTA.

The exact position of the exhaust flap is stored in a characteristic map in the Digital Motor Electronics. The following table merely provides a rough overview of the various exhaust flap states.

Engine operating points	Exhaust flap opened	Exhaust flap closed
Idling		X
Low load		X
Coasting (overrun) mode		X
Constant-speed driving with partial load		X
Acceleration with high load	X	
Full load	X	



Please note that the outer exhaust flaps on the N63TU2 engine may be closed when idling. As such, no emission measurement can be performed at these exhaust tailpipes.

# N63TU2 Engine

## 6. Vacuum System

The vacuum system of the N63TU2 engine has been modified compared with the N63TU engine. The use of the electrical wastegate valve actuator means that the vacuum reservoir and pressure converter are no longer required.

The vacuum pump on the N63TU2 engine supplies the brake servo with the required vacuum.

# N63TU2 Engine

## 7. Fuel Preparation

For the N63TU2 engine the high-pressure injection is used. It differs from high-precision injection (HPI) in that it uses solenoid valve injectors with multihole nozzles.

### 7.1. Overview

The following overview shows the fuel preparation of the N63TU2 engine. It essentially corresponds to the systems with direct fuel injection familiar in BMW models. Only the routing of the fuel delivery line to the high pressure pumps has been modified and adapted.

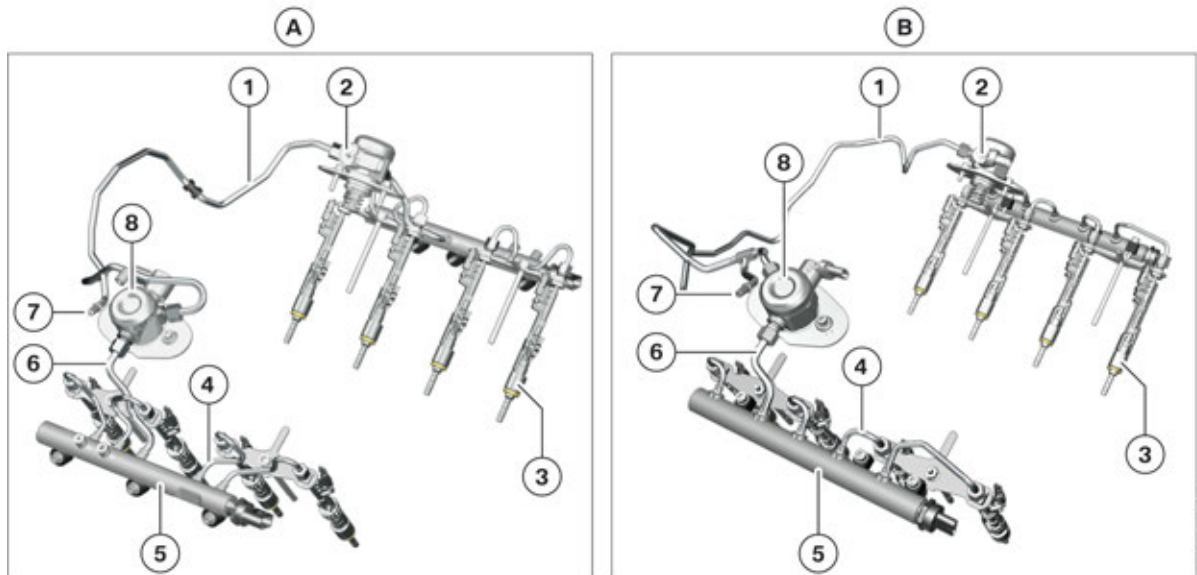

N63TU2 engine, fuel preparation

Index	Explanation
A	Fuel preparation on N63TU engine
B	Fuel preparation on N63TU2 engine
1	Fuel line
2	Fuel quantity control valve
3	Injector
4	High-pressure line, rail - injector
5	Rail
6	High pressure line, high pressure pump to rail
7	Fuel supply line
8	High pressure pump

By re-positioning the inlet bore holes at the high pressure pumps, they were moved away from the hot cylinder bank side to the cooler area.

Bosch high-pressure fuel injection valves with the designation HDEV5.2 with CVO are used. The high pressure pump is already known from the previous 4 and 8-cylinder engines.

# N63TU2 Engine

## 7. Fuel Preparation



---

Work on the fuel system is only permitted after the engine has cooled down. The coolant temperature must not exceed 40 °C. This stipulation must be observed without fail, as otherwise there is a risk of fuel being sprayed back on account of the residual pressure in the high-pressure fuel system.

When working on the high-pressure fuel system, it is essential to adhere to conditions of absolute cleanliness and to observe the work sequences described in the repair instructions. Even the slightest contamination and damage to the screwed fittings of the high-pressure lines can cause leaks.

When working on the fuel system of the N63TU2 engine, it is important to ensure that the ignition coils are not fouled with fuel. The resistance of the silicone material is greatly reduced by sustained contact with fuel. This may result in flashovers on the spark plug head and thus in misfires.

- Before making any modifications to the fuel system, it is essential to remove the ignition coils and protect the spark plug shaft against the ingress of fuel by covering with a cloth.
  - Before reinstalling the solenoid valve injectors, remove the ignition coils and ensure that conditions of greatest possible cleanliness are maintained.
  - Ignition coils heavily fouled by fuel must be replaced.
- 

### 7.2. Fuel pump control

The electric fuel pump delivers the fuel from the fuel tank via the feed line to the high pressure pump at a primary pressure of 5.9 bar. The on-load speed control is effected via the DME. The low-pressure sensor is dispensed with.

### 7.3. High pressure pump

The known Bosch high pressure pump is used. This is a single-piston pump which is driven from the exhaust camshaft via a triple cam. So that sufficient fuel pressure is guaranteed in each load condition of the engine, a high pressure pump is used in the N63TU2 engine for each bank.

For further information on the high pressure pump, please refer to ST1209 "N63 Engine" Technical Training manual.



# N63TU2 Engine

## 7. Fuel Preparation

### 7.4. Injectors

The Bosch solenoid valve injector HDEV5.2 with CVO support is an inward-opening multi-hole valve – unlike the outward-opening piezo injector used in HPI engines. The HDEV5.2 too is characterized by a high degree of variability with regard to spray angle and spray shape, and is designed for a system pressure of up to 200 bar.

These injectors are already used in the N55 and N63TU engines and in modular engines.



N63TU2 engine, injector



---

The stems of the solenoid valve injectors can only withstand a certain tensile force and a certain torque. When removing and installing the injectors it is essential to follow the specific procedure set out in the repair instructions, as otherwise the injectors may be damaged.

Due to the design, dirt particles, grains of sand etc. may enter the shafts of the injectors and spark plugs during operation, in particular in dusty environments with poor road surfaces. Before disassembly, always blow out the shafts with a sharp jet of compressed air from all possible positions and angles using a lance that is as long as possible. Once the injector or spark plug has been removed, any particles should also be cleared from the edge of the bore hole.

---

# **N63TU2 Engine**

## **8. Fuel Supply**

The fuel supply is vehicle-specific. The previously known components are used.

# N63TU2 Engine

## 9. Engine Electrical System

### 9.1. Overview

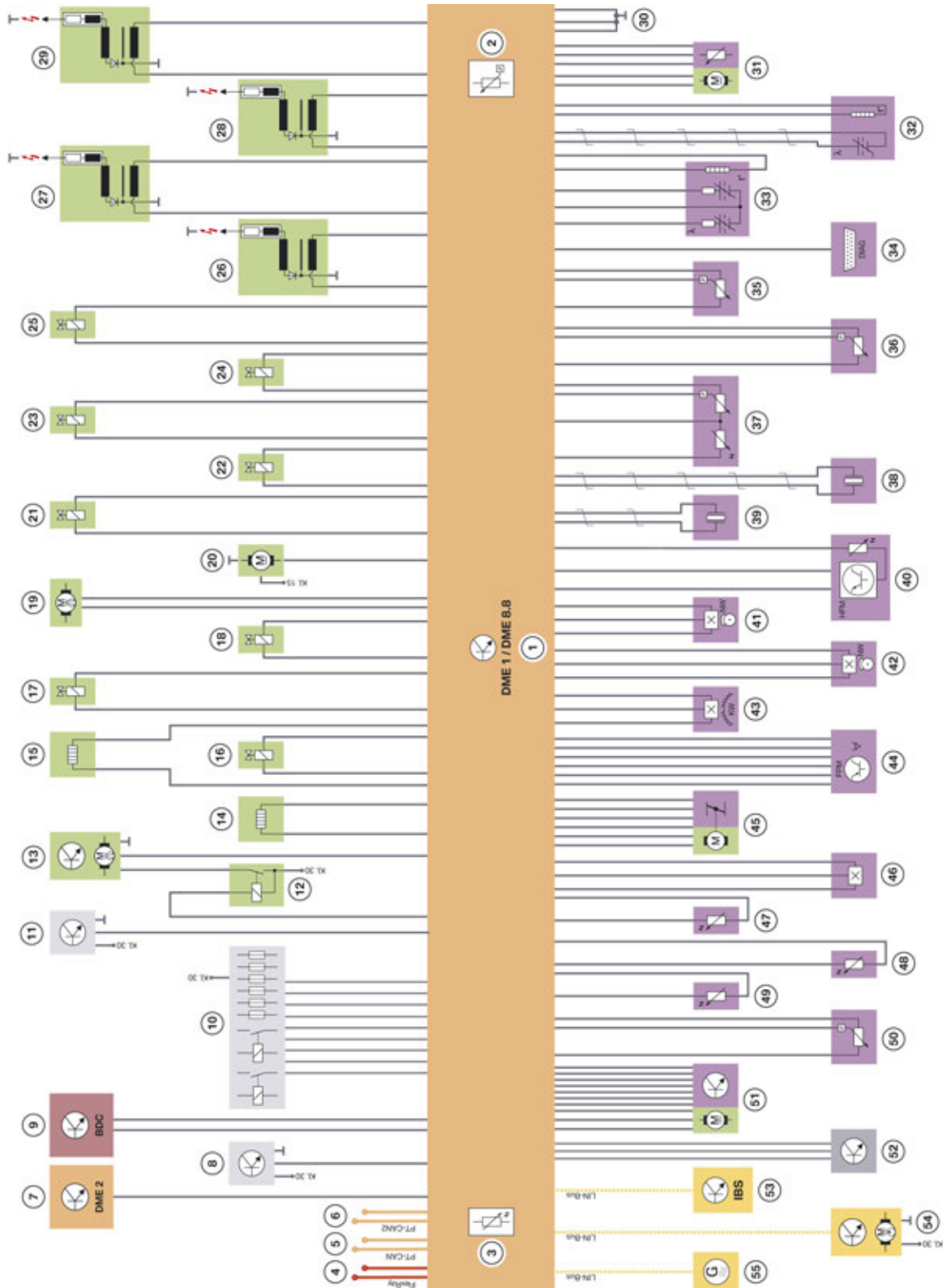

N63TU2 engine, DME 1, system wiring diagram for DME 8.8.0

TO14-1620

# N63TU2 Engine

## 9. Engine Electrical System

Index	Explanation
1	DME 1 8.8 engine electronics
2	Ambient pressure sensor
3	Temperature sensor
4	FlexRay
5	PT-CAN
6	PT-CAN2
7	DME 2 connection
8	Tank leak diagnosis, Natural Vacuum Leak Detection (NVLD)
9	Body Domain Controller (BDC)
10	Power distribution box
11	EKPS fuel pump control module
12	Relay for electric fan
13	Electric fan
14	Data-map thermostat
15	Electrical heating element of thermal actuator, coolant pump
16	Tank vent valve
17	VANOS solenoid valve, intake camshaft
18	VANOS solenoid valve, exhaust camshaft
19	Electric coolant pump, exhaust turbocharger
20	Electrical exhaust flap controller (EAKS)
21	Quantity control valve
22–25	Injectors
26–29	Ignition coils
30	Earth
31	Electrical wastegate valve actuator
32	Oxygen sensor LSF 4.2
33	Oxygen sensor LSU ADV
34	Diagnostic connector
35	Charging pressure sensor before throttle valve
36	Rail pressure sensor
37	Charge air temperature and intake-manifold pressure sensor after throttle valve
38	Knock sensors 1 – 2
39	Knock sensors 3 - 4
40	Hot film air mass meter (HFM) 8

# N63TU2 Engine

## 9. Engine Electrical System

<b>Index</b>	<b>Explanation</b>
41	Camshaft sensor, intake camshaft
42	Camshaft sensor, exhaust camshaft
43	Crankshaft sensor, signal is looped through to DME 2
44	Accelerator pedal module
45	Throttle valve
46	Travel sensor for thermostat
47	Engine temperature (sensor at housing of coolant pump)
48	Coolant temperature sensor at radiator outlet
49	Oil temperature sensor
50	Oil pressure sensor
51	Valvetronic servomotor
52	Oil level sensor
53	Intelligent Battery Sensor (IBS)
54	Electric coolant pump, charge air cooler
55	Alternator

# N63TU2 Engine

## 9. Engine Electrical System

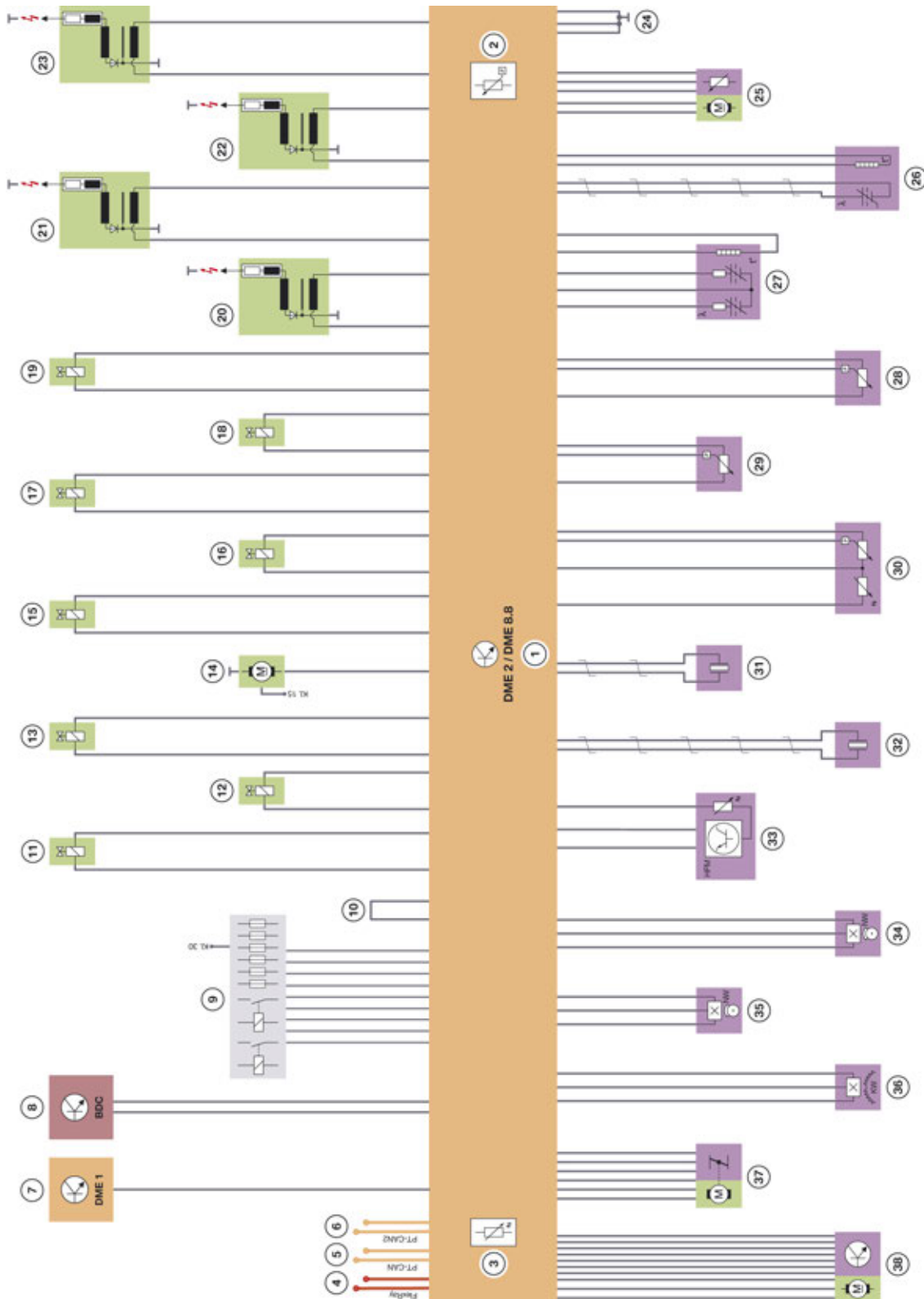

N63TU2 engine, DME 2, system wiring diagram for DME 8.8.0

# N63TU2 Engine

## 9. Engine Electrical System

<b>Index</b>	<b>Explanation</b>
1	DME 2 8.8 engine electronics
2	Ambient pressure sensor
3	Temperature sensor
4	FlexRay
5	PT-CAN
6	PT-CAN2
7	DME 1 connection
8	Body Domain Controller (BDC)
9	Power distribution box
10	DME 1–DME 2 encoding
11	VANOS solenoid valve, intake camshaft
12	VANOS solenoid valve, exhaust camshaft
13	Quantity control valve
14	Electrical exhaust flap controller (EAKS)
15	Tank vent valve
16–19	Injectors
20–23	Ignition coils
24	Earth
25	Electrical wastegate valve actuator
26	Oxygen sensor LSF 4.2
27	Oxygen sensor LSU ADV
28	Charging pressure sensor before throttle valve
29	Rail pressure sensor
30	Charge air temperature and intake-manifold pressure sensor after throttle valve
31	Knock sensors 5 - 6
32	Knock sensors 7 - 8
33	Hot film air mass meter (HFM) 8
34	Camshaft sensor, intake camshaft
35	Camshaft sensor, exhaust camshaft
36	Crankshaft sensor, signal is looped through to DME 2
37	Throttle valve
38	Valvetronic servomotor





# N63TU2 Engine

## 9. Engine Electrical System

<b>Index</b>	<b>Explanation</b>
1	Dynamic Stability Control (DSC)
2	Digital Motor Electronics (DME) 2
3	Starter motor
4	Electronic transmission control (EGS)
5	Air conditioning compressor
6	Coolant temperature sensor at radiator outlet
7	Electric fan
8	Relay for electric fan
9	Fuse, terminal 30
10	Power distribution box, front
11	Digital Motor Electronics (DME) 1
12	Accelerator pedal module
13	CAN terminator 4
14	Body Domain Controller (BDC)
15	Instrument panel (KOMBI)
16	Crash Safety Module (ACSM)
17	CAN terminator 5
18	Gear selector switch (GWS)
19	PFC fuel pump control module
20	Electric fuel pump
21	Intelligent Battery Sensor (IBS)
22	Power distribution box, rear
23	Electrical exhaust flap actuator (EAKS), right
24	Electrical exhaust flap actuator (EAKS), left

# N63TU2 Engine

## 9. Engine Electrical System

### 9.2. Engine control unit

A new generation of Bosch engine control units is used in the G12. The 8th generation of engine electronics (DME) represents a joint control unit platform for gasoline engines and is already used for modular engines. Its appearance is characterized by a uniform housing and a uniform connector strip. However, the hardware inside has been adapted to the various applications.

The control unit code (DME 8.x.yH) can be broken down as follows.

Abbreviation	Meaning
DME	Digital Motor Electronics
8	Control unit generation (modular platform for gasoline or diesel engines)
X	Number of cylinders as a hexadecimal figure
y	Vehicle electrical system architecture
H	Hybrid version

Number of cylinders as a hexadecimal figure:

- 3 = 3-cylinder engine
- 4 = 4-cylinder engine
- 6 = 6-cylinder engine
- 8 = 8-cylinder engine
- C = 12-cylinder engine

Vehicle electrical system architecture:

- 0 = vehicle electrical system 1 (large series)
- 1 = vehicle electrical system 2 (small series)

Examples for Gasoline engines:

- DME 8.4.0H = B48 PHEV\* (vehicle electrical system 1)
- DME 8.6.1 = B58 (vehicle electrical system 2)
- DME 8.8.0 = N63TU2 (vehicle electrical system 1)
- DME 8.C.0 = N74TU (vehicle electrical system 1)

\*PHEV = Plug-in Hybrid Electric Vehicle.

As such, the N63TU2 engine has Bosch Digital Motor Electronics with the designation DME 8.8.0. There is a separate water-cooled engine control unit fixed to the engine for every bank. The actuators and sensors of cylinder bank 1 are assigned to the DME 1 control unit; accordingly, the DME 2 control unit is responsible for the functions of cylinder bank 2. DME 1 is the main control unit and receives all information concerning the entire engine, such as regarding the crankshaft sensor, and provides it to the DME 2 control unit directly or via the bus system. Due to the variety of sensors and actuators it was deemed necessary to use 2 control units.

# N63TU2 Engine

## 9. Engine Electrical System

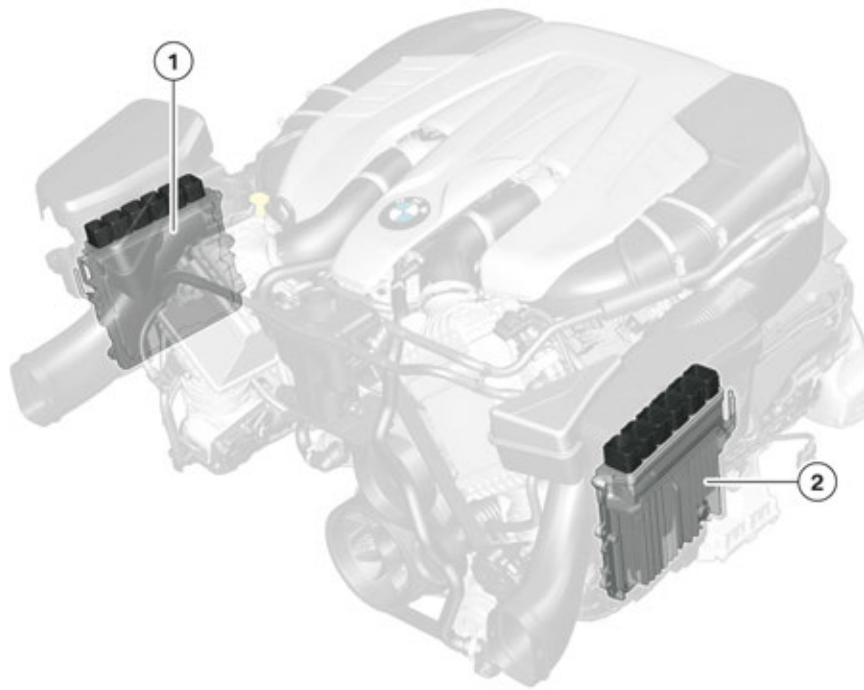

TO14-1389

N63TU2 engine, Digital Motor Electronics

Index	Explanation
1	DME control unit, bank 1
2	DME control unit, bank 2



Do not attempt any trial replacement of control units.

Because of the electronic immobilizer, a trial replacement of control units from other vehicles must not be attempted under any circumstances. An immobilizer adjustment cannot be reversed.

The cooling of the two control units of the Digital Motor Electronics is effected in the N63TU2 engine by connection to the cooling circuit of the charge air cooling. In this system, an aluminium cooling loop is integrated into the housing of the control units.

The connector concept is identical to that on the modular engines and features a Nano MQS connector system (Micro Quadlok System). There is a logical division into 6 modules.



Measurements on the wiring harness may only be taken using measuring procedures approved by BMW. The use of incorrect tools such as gauge tips will damage the plug-in contacts.

# N63TU2 Engine

## 9. Engine Electrical System

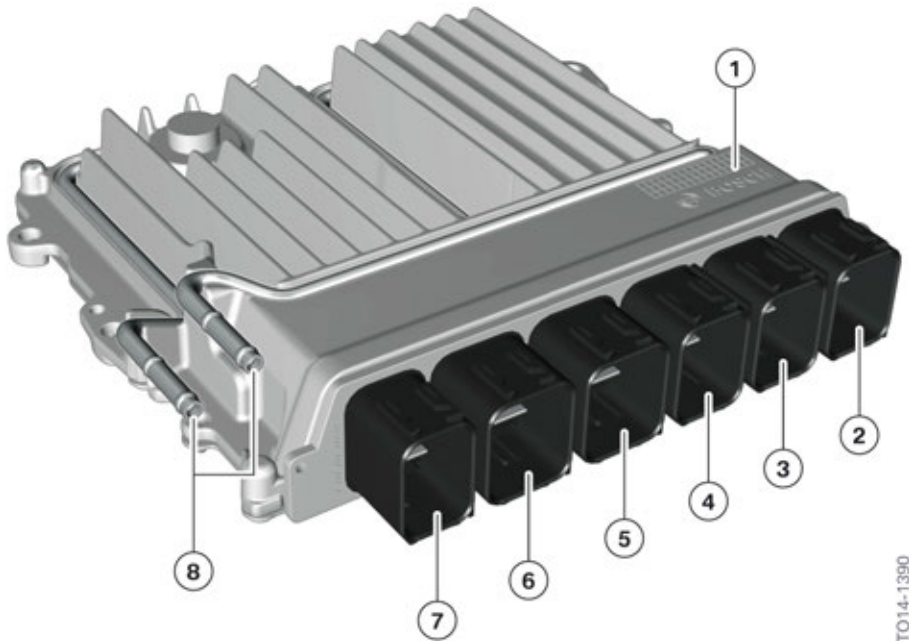

N63TU2 engine, connections for DME 8.8.0

Index	Explanation
1	DME engine control unit 8.8
2	Module 100, vehicle connection
3	Module 200, sensors and actuators 1
4	Module 300, sensors and actuators 2
5	Module 400, Valvetronic servomotor
6	Module 500, DME supply
7	Module 600, injection and ignition
8	Coolant connections

### 9.2.1. Overall function

The Digital Motor Electronics (DME) is the computing and switching center of the engine control system. Sensors on the engine and the vehicle deliver the input signals. The signals for activating the actuators are calculated from the input signals, the nominal values calculated using a computing model in the DME control unit and the stored program maps. The DME control unit activates the actuators directly or via relays.

The DME control unit is woken up by the Body Domain Controller (BDM) via the wake-up line (terminal 15 Wake up).

The after-run starts after terminal 15 OFF. The adaptation values are stored during the after-run. The DME control unit uses a bus signal to signal its readiness to "go to sleep". When all the participating control units have signalled their readiness to "go to sleep", the bus master outputs a bus signal and the control units terminate communication 5 seconds later.

# N63TU2 Engine

## 9. Engine Electrical System

The printed circuit board in the DME control unit accommodates 2 sensors: a temperature sensor and an ambient pressure sensor. The temperature sensor is used to monitor the temperature of the components in the DME control unit. The ambient pressure is required for calculating the mixture composition.

### 9.3. Alternator

The N63TU2 engine uses an alternator with a power of 252 A. A new feature is that the alternator does not rectify the supplied AC voltage using diodes as usual. As on the modular engines, rectification is carried out by an actively controlled metal-oxide semiconductor field-effect transistor. The use of the actively controlled metal-oxide semiconductor field-effect transistor to rectify the AC voltage has increased efficiency compared with the power diodes that are otherwise used. Thanks to this increased efficiency, the rectification process has been made more efficient within the installation space, which in turn lowers carbon dioxide emissions.



Bayerische Motorenwerke Aktiengesellschaft  
Qualifizierung und Training  
Röntgenstraße 7  
85716 Unterschleißheim, Germany